

A  
B  
C  
D  
E  
F  
PS  
H  
I  
J  
K  
L  
M

# SECTION PS

## POWER STEERING SYSTEM

### CONTENTS

<b>PRECAUTIONS</b> .....	<b>3</b>	Components (with Automatic Drive Positioner) .....	17
Precautions for Supplemental Restraint System (SRS) "AIR BAG" and "SEAT BELT PRE-TENSIONER" .....	3	Disassembly and Assembly .....	18
Precautions Necessary for Steering Wheel Rotation After Battery Disconnect .....	3	DISASSEMBLY .....	18
OPERATION PROCEDURE .....	3	ASSEMBLY .....	18
Precautions for Steering System .....	3	<b>POWER STEERING GEAR AND LINKAGE</b> .....	<b>19</b>
<b>PREPARATION</b> .....	<b>5</b>	Removal and Installation .....	19
Special Service Tools (SST) .....	5	REMOVAL .....	19
Commercial Service Tools .....	6	INSTALLATION .....	20
<b>NOISE, VIBRATION AND HARSHNESS (NVH)</b>		INSPECTION AFTER INSTALLATION .....	21
<b>TROUBLESHOOTING</b> .....	<b>7</b>	Disassembly and Assembly .....	22
NVH Troubleshooting Chart .....	7	DISASSEMBLY .....	23
<b>POWER STEERING FLUID</b> .....	<b>8</b>	INSPECTION AFTER DISASSEMBLY .....	25
Checking Fluid Level .....	8	ASSEMBLY .....	26
Checking Fluid Leakage .....	8	<b>POWER STEERING OIL PUMP</b> .....	<b>31</b>
Air Bleeding Hydraulic System .....	8	On-Vehicle Inspection and Service .....	31
<b>STEERING WHEEL</b> .....	<b>10</b>	CHECKING RELIEF OIL PRESSURE (VQ35DE MODELS) .....	31
On-Vehicle Inspection and Service .....	10	CHECKING RELIEF OIL PRESSURE (VK45DE MODELS) .....	31
CHECKING CONDITION OF INSTALLATION ...	10	Removal and Installation (VQ35DE Models) .....	32
CHECKING STEERING WHEEL PLAY .....	10	REMOVAL .....	32
CHECKING NEUTRAL POSITION ON STEERING WHEEL .....	10	INSTALLATION .....	33
CHECKING STEERING WHEEL TURNING FORCE .....	10	Removal and Installation (VK45DE Models) .....	33
CHECKING FRONT WHEEL TURNING ANGLE..	11	REMOVAL .....	33
Removal and Installation .....	11	INSTALLATION .....	33
<b>STEERING COLUMN</b> .....	<b>12</b>	Disassembly and Assembly (VQ35DE Models) ....	33
Removal and Installation .....	12	INSPECTION BEFORE DISASSEMBLY .....	33
REMOVAL .....	12	DISASSEMBLY .....	34
INSPECTION AFTER REMOVAL .....	14	INSPECTION AFTER DISASSEMBLY .....	34
INSTALLATION .....	14	ASSEMBLY .....	35
INSPECTION AFTER INSTALLATION .....	14	Disassembly and Assembly (VK45DE Models) ....	37
Components (without Automatic Drive Positioner)..	15	INSPECTION BEFORE DISASSEMBLY .....	37
Disassembly and Assembly .....	15	DISASSEMBLY .....	38
DISASSEMBLY .....	15	INSPECTION AFTER DISASSEMBLY .....	38
ASSEMBLY .....	16	ASSEMBLY .....	38
		<b>HYDRAULIC LINE</b> .....	<b>41</b>
		Components .....	41
		Removal and Installation .....	43
		Component .....	44
		Removal and Installation .....	45

---

<b>SERVICE DATA AND SPECIFICATIONS (SDS) .....</b>	<b>46</b>	Steering Outer Socket and Inner Socket .....	46
Steering Wheel .....	46	Steering Gear .....	47
Steering Angle .....	46	Oil Pump .....	47
Steering Column .....	46	Steering Fluid .....	47

# PRECAUTIONS

## PRECAUTIONS

PFP:00001

### Precautions for Supplemental Restraint System (SRS) “AIR BAG” and “SEAT BELT PRE-TENSIONER”

AGS000GO

The Supplemental Restraint System such as “AIR BAG” and “SEAT BELT PRE-TENSIONER”, used along with a front seat belt, helps to reduce the risk or severity of injury to the driver and front passenger for certain types of collision. This system includes seat belt switch inputs and dual stage front air bag modules. The SRS system uses the seat belt switches to determine the front air bag deployment, and may only deploy one front air bag, depending on the severity of a collision and whether the front occupants are belted or unbelted. Information necessary to service the system safely is included in the SRS and SB section of this Service Manual.

#### **WARNING:**

- To avoid rendering the SRS inoperative, which could increase the risk of personal injury or death in the event of a collision which would result in air bag inflation, all maintenance must be performed by an authorized NISSAN/INFINITI dealer.
- Improper maintenance, including incorrect removal and installation of the SRS, can lead to personal injury caused by unintentional activation of the system. For removal of Spiral Cable and Air Bag Module, see the SRS section.
- Do not use electrical test equipment on any circuit related to the SRS unless instructed to in this Service Manual. SRS wiring harnesses can be identified by yellow and/or orange harnesses or harness connectors.

### Precautions Necessary for Steering Wheel Rotation After Battery Disconnect

AGS000L3

#### **NOTE:**

- This Procedure is applied only to models with Intelligent Key system and NVIS/IVIS (NISSAN/INFINITI VEHICLE IMMOBILIZER SYSTEM - NATS).
- Remove and install all control units after disconnecting both battery cables with the ignition knob in the “LOCK” position.
- Always use CONSULT-II to perform self-diagnosis as a part of each function inspection after finishing work. If DTC is detected, perform trouble diagnosis according to self-diagnostic results.

For models equipped with the Intelligent Key system and NVIS/IVIS, an electrically controlled steering lock mechanism is adopted on the key cylinder.

For this reason, if the battery is disconnected or if the battery is discharged, the steering wheel will lock and steering wheel rotation will become impossible.

If steering wheel rotation is required when battery power is interrupted, follow the procedure below before starting the repair operation.

#### **OPERATION PROCEDURE**

1. Connect both battery cables.

#### **NOTE:**

Supply power using jumper cables if battery is discharged.

2. Use the Intelligent Key or mechanical key to turn the ignition switch to the “ACC” position. At this time, the steering lock will be released.
3. Disconnect both battery cables. The steering lock will remain released and the steering wheel can be rotated.
4. Perform the necessary repair operation.
5. When the repair work is completed, return the ignition switch to the “LOCK” position before connecting the battery cables. (At this time, the steering lock mechanism will engage.)
6. Perform a self-diagnosis check of all control units using CONSULT-II.

### Precautions for Steering System

AGS000GP

- Before disassembly, thoroughly clean the outside of the unit.
- Disassembly should be done in a clean work area. It is important to prevent the internal parts from becoming contaminated by dirt or other foreign matter.
- For easier and proper assembly, place disassembled parts in order on a parts rack.

## PRECAUTIONS

---

- Use nylon cloth or paper towels to clean the parts; common shop rags can leave lint that might interfere with their operation.
- Before inspection or reassembly, carefully clean all parts with a general purpose, non-flammable solvent.
- Before assembly, apply a coat of recommended Genuine NISSAN PSF or equivalent to hydraulic parts. Petroleum jelly may be applied to O-rings and seals. Do not use any grease.
- Replace all gaskets, seals and O-rings. Avoid damaging O-rings, seals and gaskets during installation. Perform functional tests whenever designated.

# PREPARATION

## PREPARATION

PF0:00002

### Special Service Tools (SST)

AGS000G0

The actual shapes of Kent-Moore tools may differ from those of special service tools illustrated here.

A  
B  
C  
D  
E  
F  
PS  
H  
I  
J  
K  
L  
M

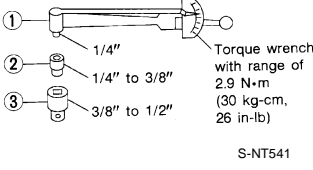
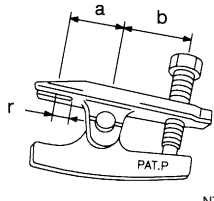
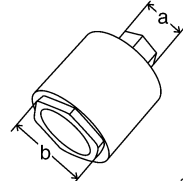
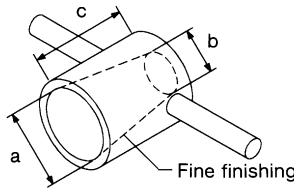
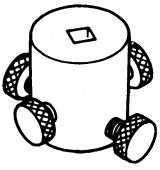
Tool number (Kent-Moore No.) Tool name	Description
ST3127 S000 (See J25765-A) Preload gauge 1. GG9103000 (J25765-A) Torque wrench 2. HT62940000 ( — ) Socket adapter 3. HT62900000 ( — ) Socket adapter	 <p>Inspecting of sliding torque, steering torque, and rotating torque for ball joint</p>
HT72520000 (J25730-A) Ball joint remover a: 33 mm (1.30 in) b: 50 mm (1.97 in) r: 11.5 mm (0.453 in)	 <p>Removing steering outer socket</p>
KV4810 5400 (J-46213) Rear cover wrench a: 21.6 mm (0.850 in) b: 34.9 mm (1.374 in)	 <p>Removing rear cover</p>
KV48104400 ( — ) Teflon ring correcting tool a: 50 mm (1.97 in) dia. b: 36 mm (1.42 in) dia. c: 100 mm (3.94 in)	 <p>Installing of rack Teflon ring</p>
KV48103400 ( — ) Torque adapter	 <p>Inspecting rotating torque</p>

# PREPARATION

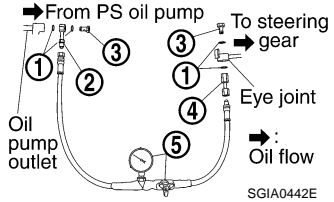
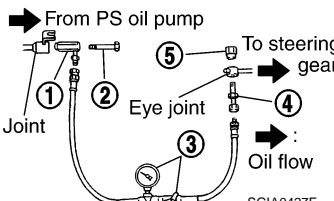
Tool number (Kent-Moore No.) Tool name	Description
1. KV48102500-04 (      —      ) Washer 2. KV48102500-01 (      —      ) Eye joint 3. KV48102500-03 (      —      ) Bolt 4. KV48102500-02 (      —      ) Flare Joint 5. KV48103500 (J26357&J26357-10) Pressure gauge & shut off valve	 <p style="text-align: right; font-size: small;">SGIA0442E</p> <p style="text-align: center;">Measuring oil pump relief pressure (VQ35DE models)</p>
1. KV48105300-4 and 5295262U10 (      —      ) Connector A and O-ring 2. KV48105300-3 and 5295262U00 (      —      ) Eye-bolt and O-ring 3. KV48103500 (J26357 and J26357-10) Pressure gauge and shut-off valve 4. KV48105300-1 and 5295262U00 (      —      ) Connector B and O-ring 5. KV48105300-2 (      —      ) Nut	 <p style="text-align: right; font-size: small;">SGIA0427E</p> <p style="text-align: center;">Measuring oil pump relief pressure (VK45DE models)</p>

## Commercial Service Tools

AGS000GR

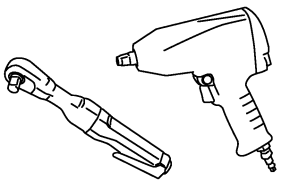
Tool name	Description
Power tool	 <p style="text-align: right; font-size: x-small;">PBIC0190E</p> <ul style="list-style-type: none"> <li>● Removing wheel nuts</li> <li>● Removing undercover</li> <li>● Removing steering gear</li> </ul>

# NOISE, VIBRATION AND HARSHNESS (NVH) TROUBLESHOOTING

## NOISE, VIBRATION AND HARSHNESS (NVH) TROUBLESHOOTING

PPF:00003

### NVH Troubleshooting Chart

AGS000GS

Use chart below to help you find the cause of the symptom. If necessary, repair or replace these parts.

Symptom	STEERING	Possible cause and suspected parts														Reference page										
		Fluid level	Air in hydraulic system	Outer socket ball joint swinging force	Outer socket ball joint rotating torque	Outer socket ball joint end play	Steering fluid leakage	Steering wheel play	Steering gear rack sliding force	Drive belt looseness	Improper steering wheel	Improper installation or looseness of tilt lock lever	Mounting rubber deterioration	Steering column deformation or damage	Improper installation or looseness of steering column		Steering linkage looseness	PROPELLER SHAFT	DIFFERENTIAL	AXLE and SUSPENSION	TIRES	ROAD WHEEL	DRIVE SHAFT	BRAKES		
Noise	STEERING	Noise	x	x	x	x	x	x	x	x	x	x	x	x	x	x	x	x	x	x	x	x	x	x	PS-8	
		Shake																								PS-8
		Vibration																								PS-25
		Shimmy																								PS-25
		Judder																								PS-8
Shake	STEERING	Noise																							PS-10	
		Shake																								PS-10
		Vibration																								EM-15, EM-16Z
		Shimmy																								PS-10
		Judder																								PS-10
Vibration	STEERING	Noise																								PS-12
		Shake																								PS-12
		Vibration																								PS-19
		Shimmy																								PS-12
		Judder																								PS-12
Shimmy	STEERING	Noise																								PS-19
		Shake																								PS-19
		Vibration																								NVH in PR section
		Shimmy																								NVH in RFD section
		Judder																								NVH in FAX, RAX, FSU, RSU section
Judder	STEERING	Noise																								NVH in WT section
		Shake																								NVH in WT section
		Vibration																								NVH in FAX section
		Shimmy																								NVH in BR section
		Judder																								NVH in BR section

x: Applicable

A  
B  
C  
D  
E  
F  
PS  
H  
I  
J  
K  
L  
M

# POWER STEERING FLUID

## POWER STEERING FLUID

PFP:KLF20

### Checking Fluid Level

AGS000GT

- Stop engine before performing a fluid level check.
- Ensure that fluid level is between the MAX range and MIN level.
- Because fluid level differs within the HOT range and the COLD range, check it carefully.

**HOT** : Fluid temperatures from 50 to 80 °C (122 to 176 °F)

**COLD** : Fluid temperatures from 0 to 30 °C (32 to 86°F)

#### CAUTION:

- Do not overfill the Max level.
- Do not reuse any used power steering fluid.
- Recommended fluid is Genuine NISSAN PSF or equivalent.

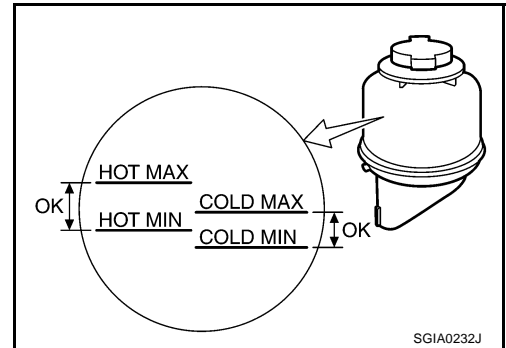

### Checking Fluid Leakage

AGS000GU

Check the hydraulic piping lines for improper attachment and for leaks, cracks, damage, loose connections, chafing or deterioration.

1. Run engine until fluid temperature reaches 50 to 80° C (122 to 176°F) in reservoir tank. Keep engine speed idle.
2. Turn steering wheel right-to-left several times.
3. Hold steering wheel at each "lock" position for five seconds to check fluid leakage.

#### CAUTION:

**Do not hold steering wheel in a locked position for more than 10 seconds. (There is the possibility that oil pump may be damaged.)**

4. If fluid leakage at connections is noticed, then loosen flare nut and then retighten. Do not over tighten connector as this can damage O-ring, washer and connector.
5. If fluid leakage from oil pump is noticed, check oil pump. Refer to [PS-31, "POWER STEERING OIL PUMP"](#).
6. Check steering gear boots for accumulation of fluid indicating a from steering gear.

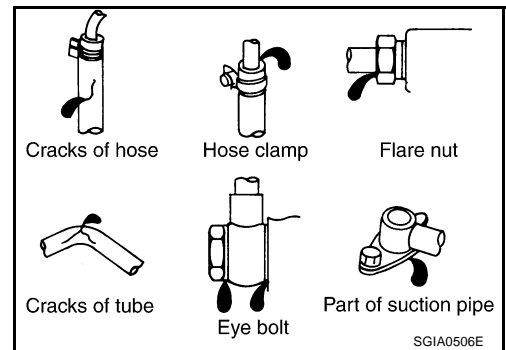

### Air Bleeding Hydraulic System

AGS000GV

Incomplete air bleeding causes the following. When this happens, bleed air again.

- Generation of air bubbles in reservoir tank.
- Generation of clicking noise in oil pump.
- Excessive buzzing in oil pump.

#### NOTE:

When vehicle is stationary or while steering wheel is being turned slowly, some noise may be heard from oil pump or gear. This noise is normal and does not affect any system.

1. Stop engine, and then turn steering wheel fully to right and left several times.

#### CAUTION:

**Do not allow steering fluid reservoir tank to go below the low-level line. Check tank frequently and add fluid as needed.**

2. Run engine at idle speed. Turn steering wheel fully to the right and then fully to the left, and keep for about three seconds. Then check whether a fluid leakage has occurred.
3. Repeat the 2nd procedure several times at about three seconds intervals.

#### CAUTION:

**Do not hold steering wheel in the locked position more than 10 seconds. (There is the possibility that oil pump may be damaged.)**

4. Check generation of air bubbles and cloud in fluid.



## POWER STEERING FLUID

---

5. If air bubbles and the cloud don't fade, stop engine, hold air bleeding until air bubbles and the cloud fade. Perform the 2nd and the 3rd procedures again.
6. Stop engine, check fluid level.

A

B

C

D

E

F

PS

H

I

J

K

L

M

# STEERING WHEEL

## STEERING WHEEL

PFP:48430

### On-Vehicle Inspection and Service CHECKING CONDITION OF INSTALLATION

AGS000GW

- Check installation condition of steering gear assembly, front suspension, axle and steering column.
- Check if movement exists when steering wheel is moved up and down, to the left and right and to the axial direction.

**End play of the axle direction for steering wheel : 0 mm (0 in)**

- Check if the mounting bolts for steering gear assembly are loose or not. Refer to [PS-19, "POWER STEERING GEAR AND LINK-AGE"](#).

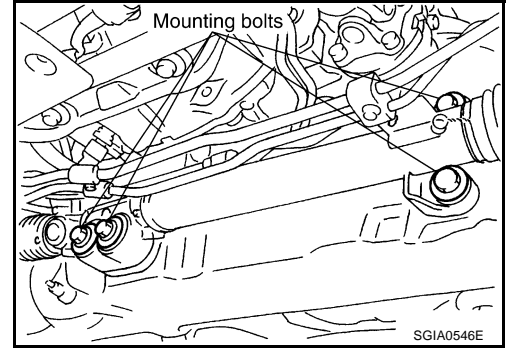

### CHECKING STEERING WHEEL PLAY

1. Set tires to the straight ahead, start engine, then turn steering wheel to the left and right lightly, and measure steering wheel movement on the outer circumference when steering wheel is turned up to the point where tires start moving.

**Steering wheel play on the outer circumference : 0 – 35 mm (0 – 1.38 in)**

### CHECKING NEUTRAL POSITION ON STEERING WHEEL

Check neutral position on steering wheel after confirming that front wheel alignment is correct. Refer to [FSU-6, "Wheel Alignment Inspection"](#).

1. Set vehicle to the straight direction, check if steering wheel is in the neutral position.
2. If it is not in the neutral position, remove steering wheel and reinstall it correctly.
3. If the neutral position cannot adjust in the two teeth of steering gear assembly, loosen outer socket lock nuts of steering outer sockets, then adjust outer socket by the same amount in the opposite direction.

### CHECKING STEERING WHEEL TURNING FORCE

1. Park vehicle on a level and dry surface, set parking brake.
2. Remove driver air bag module from steering wheel. Refer to [SRS-37, "DRIVER AIR BAG MODULE"](#).
3. Start engine at idle, make steering fluid reach to normal operating temperature [50 to 80°C (122 to 176°F)], then check steering wheel turning torque with pre-load gauge (SST).

**Turning torque : 7.45 N-m (0.76 kg-m, 66 in-lb) or less**

4. If steering wheel turning force is out of the specification, check relief hydraulic pressure of oil pump. Refer to [PS-31, "POWER STEERING OIL PUMP"](#).

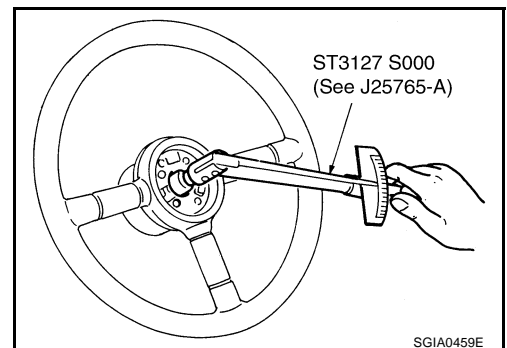

# STEERING WHEEL

## CHECKING FRONT WHEEL TURNING ANGLE

- Check front wheel turning angle after the toe-in inspection. Place front wheels on turning radius gauges and rear wheels on stands so that vehicle can be level. Check the maximum inner and outer wheel turning angles for LH and RH road wheels.

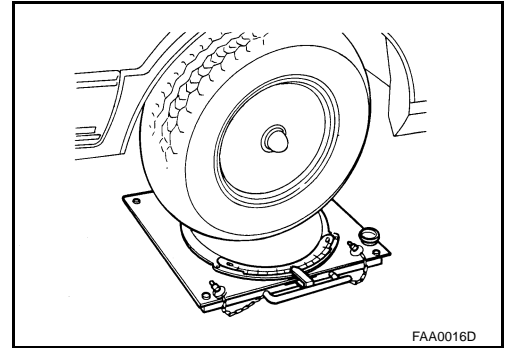

- Start engine and run at idle, turn steering wheel all the way right and left, measure the turning angle.

Tire Size		18 inch and 20 inch
Inner wheel (Angle: A)	Minimum	32°00' (32.0°)
	Nominal	35°00' (35.0°)
	Maximum	36°00' (36.0°)
Outer wheel (Angle: B)	Nominal	30°00' (30.0°)

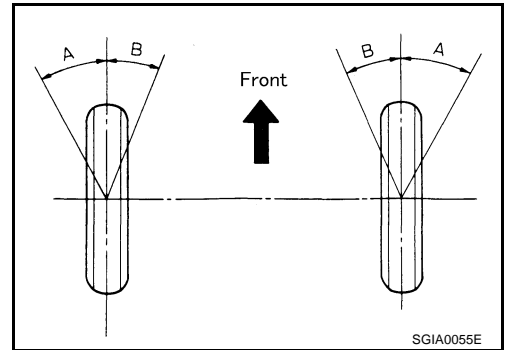

- Any turning angles are not adjustable. If any of steering angles are out of the specification, check if the following parts are wear or damaged.
  - Steering gear
  - Steering column
  - Front suspension components
 If found that they are worn or damaged, replace them with new ones respectively.

## Removal and Installation

Refer to [PS-12, "STEERING COLUMN"](#) .

AGS000GX

# STEERING COLUMN

PFP:48810

## STEERING COLUMN

### Removal and Installation

AGS000GY

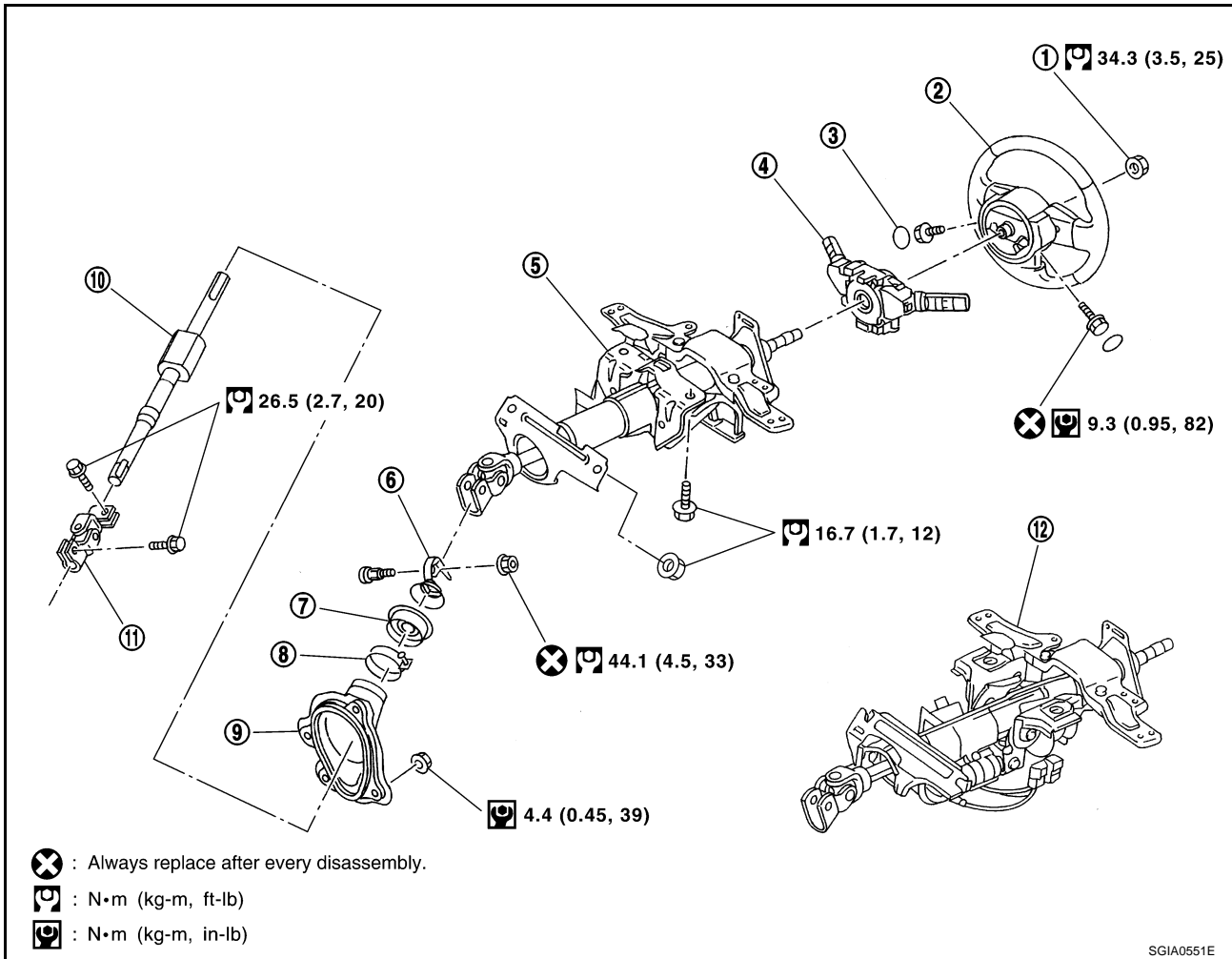

- |                                      |                             |  |
|--------------------------------------|-----------------------------|--|
| 1. Steering wheel lock nut           | 2. Steering wheel           | 3. Lid   |
| 4. Combination switch & spiral cable | 5. Steering column assembly | 6. Collar  |
| 7. Hole cover seal                   | 8. Clamp                    | 9. Hole cover  |
| 10. Lower shaft                      | 11. Lower joint             | 12. Steering column assembly (with Automatic Drive Positioner) |

### CAUTION:

- Care must be taken not to give axial impact to steering column assembly during removal and installation.
- Care must be taken not to move steering gear during removal of steering column assembly.

### REMOVAL

1. Set vehicle to the straight ahead-direction.
2. Remove driver air bag module from steering wheel. Refer to [SRS-37, "DRIVER AIR BAG MODULE"](#).
3. Disconnect steering switch connector, remove steering wheel lock nut, then remove steering wheel. Refer to [SRS-39, "SPIRAL CABLE"](#).
4. Remove steering column cover. Refer to [IP-10, "INSTRUMENT PANEL ASSEMBLY"](#).
5. Remove combination switch & spiral cable from steering column assembly. Refer to [SRS-39, "SPIRAL CABLE"](#).
6. Remove instrument lower panel (driver side). Refer to [IP-10, "INSTRUMENT PANEL ASSEMBLY"](#).
7. Remove combination meter. Refer to [IP-10, "INSTRUMENT PANEL ASSEMBLY"](#).

## STEERING COLUMN

8. Remove fixing bolts of knee protector, then remove knee protector from vehicle.
9. Disconnect harness connector from each switch on steering column shaft, then separate vehicle side harness from it.

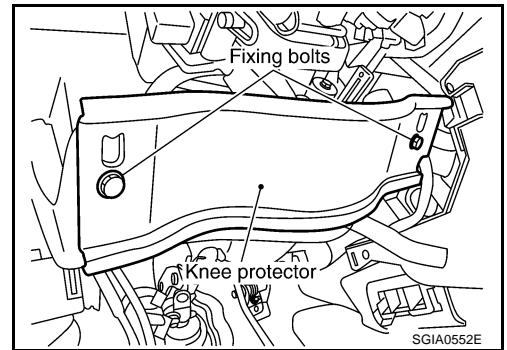

10. Remove lock nut and bolt, then separate lower shaft from upper joint of steering column assembly.

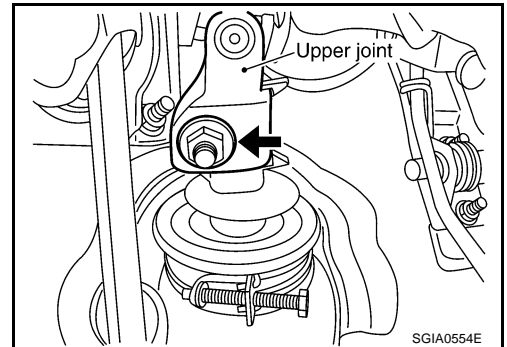

11. Remove fixing bolts and nuts from steering member, remove steering column assembly from steering member.
12. Remove hole cover seal and clamp.
13. Remove mounting nuts, then remove hole cover from panel.

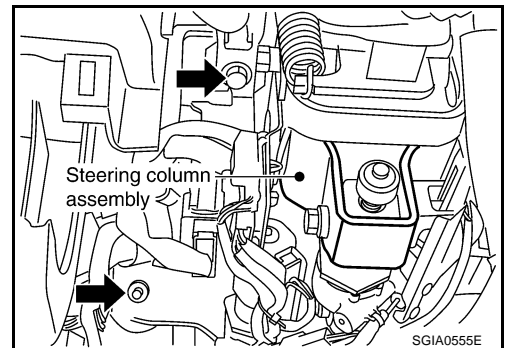

14. Raise vehicle, then remove mounting bolts of lower joint.
15. Remove lower joint and lower shaft from vehicle.

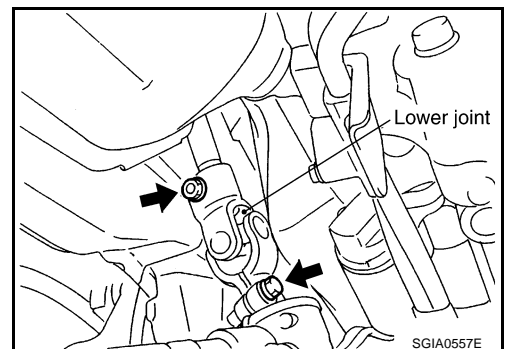

A  
B  
C  
D  
E  
F  
PS  
H  
I  
J  
K  
L  
M

# STEERING COLUMN

## INSPECTION AFTER REMOVAL

- Check if there is something wrong with jacket tube of steering column assembly and collar etc. And then if they are damaged, replace with new one.
- If vehicle has a collision light shocked, check column length "L" as shown in the figure. Then if it is out of the specified value, replace with new one.

**Steering column length "L": 572 mm (22.52 in)**

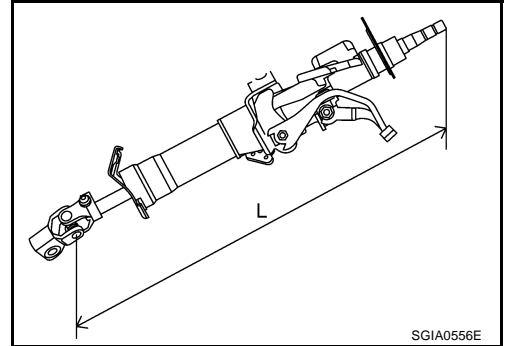

- Check the turning torque of steering column with preload gauge (SST). If it is out of the specified value, repair it or replace with new one.

**Turning torque : 0 – 0.2 N·m (0 – 0.021 kg·m, 0 – 1 in·lb)**

## INSTALLATION

- Refer to [PS-12. "Removal and Installation"](#) for tightening torque. Install in the reverse order of removal.

### NOTE:

Refer to component parts location and do not reuse non-reusable parts.

- After removing/installing or replacing steering components, check wheel alignment. Refer to [FSU-6. "Wheel Alignment Inspection"](#) .
- After adjusting wheel alignment, adjust neutral position of steering angle sensor. Refer to [BRC-6. "Adjustment of Steering Angle Sensor Neutral Position"](#) .

## INSPECTION AFTER INSTALLATION

- After installing steering column to vehicle, check tilt device and its operation range. Ranges of operation are shown in the figure.
- Check if steering wheel operation can turn to the end of the left and right smoothly.

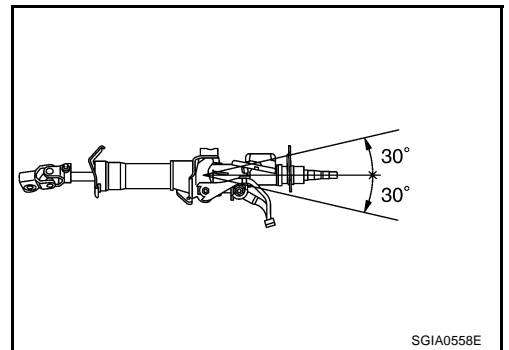

# STEERING COLUMN

## Components (without Automatic Drive Positioner)

AGS000GZ

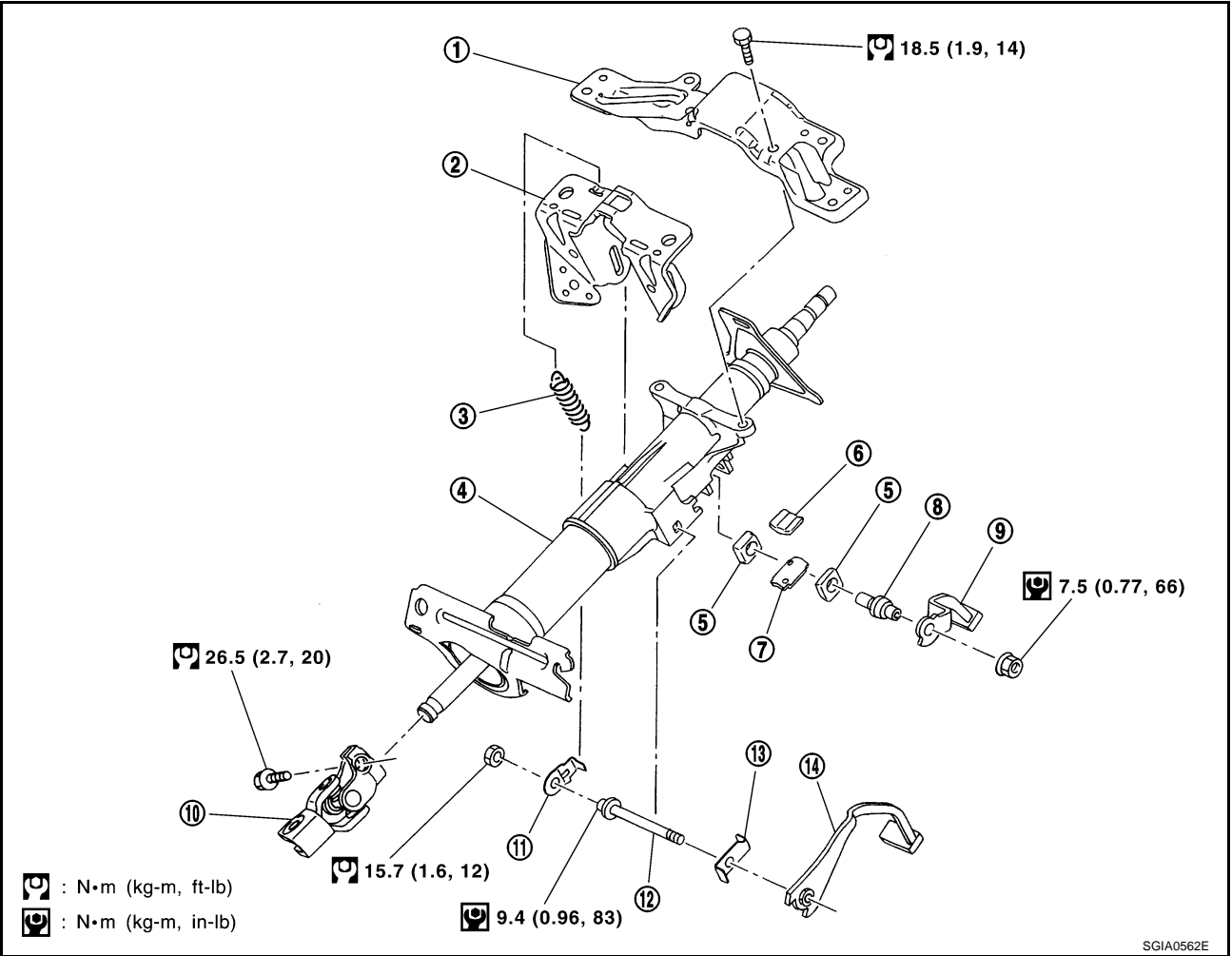

- |                          |                                   |                          |
|--------------------------|-----------------------------------|--------------------------|
| 1. Meter bracket         | 2. Steering column mounting clamp | 3. Spring                |
| 4. Jacket tube assembly  | 5. Lock nut                       | 6. Telescopic lock block |
| 7. Telescopic lock guide | 8. Telescopic lock bolt           | 9. Telescopic lever      |
| 10. Upper joint          | 11. Adjuster stopper              | 12. Steering adjust bolt |
| 13. Tilt lever stopper   | 14. Tilt lever                    |                          |

### Disassembly and Assembly DISASSEMBLY

AGS000HK

Remove all parts from jacket tube assembly.

- When remove tilt lever, perform as shown in the figure.

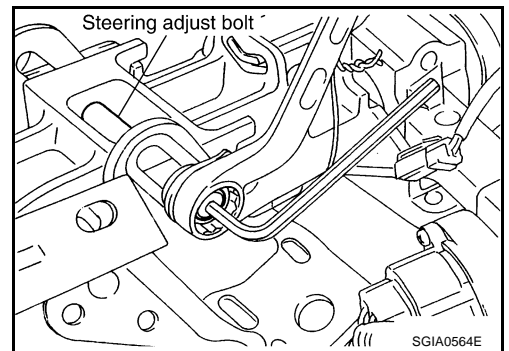

## STEERING COLUMN

- When remove telescopic lever, perform as shown in the figure.

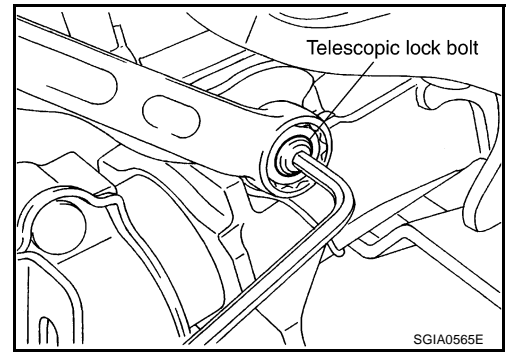

### ASSEMBLY

Refer to [PS-15. "Components \(without Automatic Drive Positioner\)"](#) for tightening torque. Install in the reverse order of disassembly.



# STEERING COLUMN

## Components (with Automatic Drive Positioner)

AGS000HH

A  
B  
C  
D  
E  
F  
PS  
H  
I  
J  
K  
L  
M

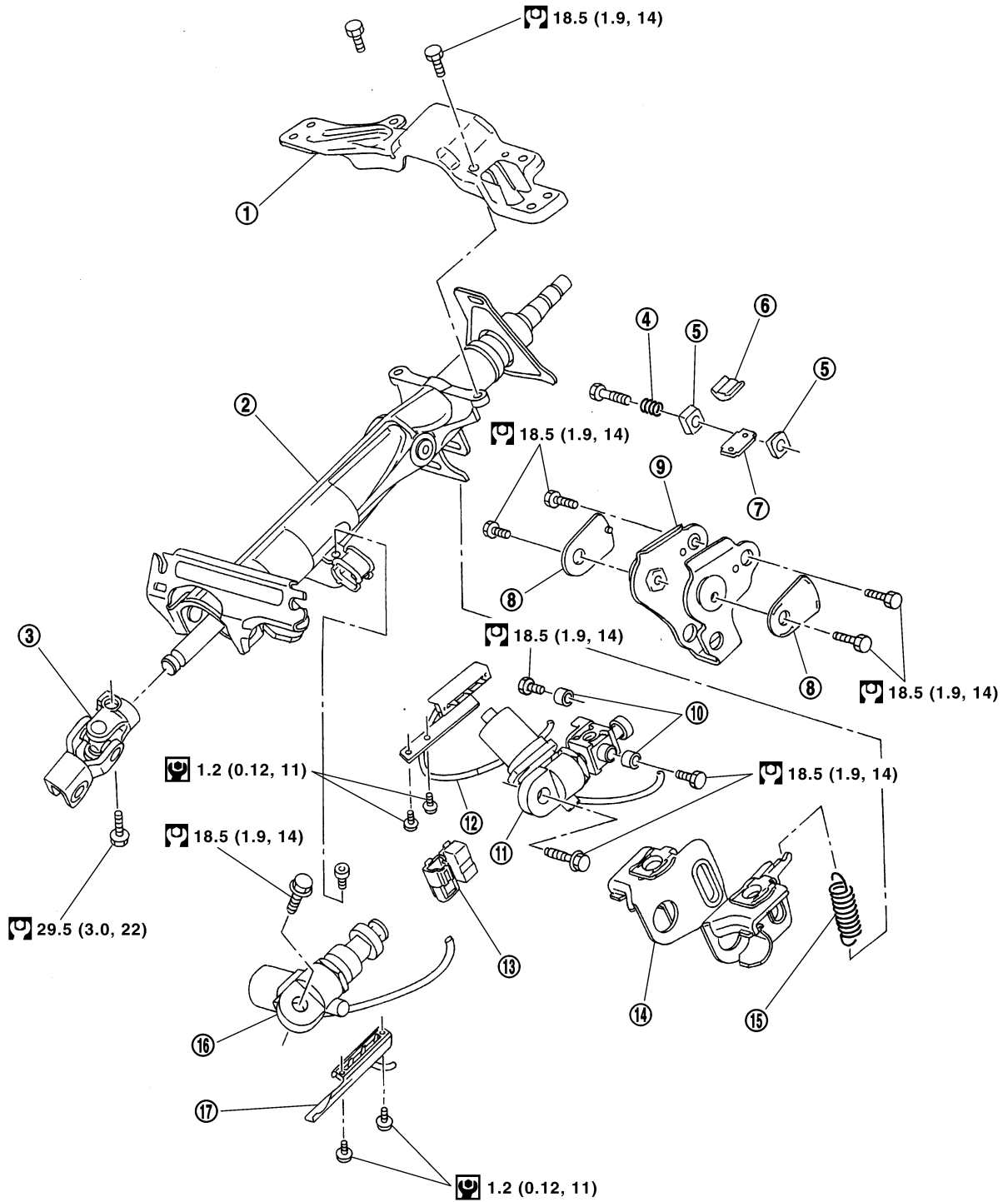

: N•m (kg-m, ft-lb)  
 : N•m (kg-m, in-lb)

SGIA0592E

# STEERING COLUMN

---

- |                              |                                |                          |
|------------------------------|--------------------------------|--------------------------|
| 1. Meter bracket             | 2. Jacket tube assembly        | 3. Upper joint           |
| 4. Spring                    | 5. Lock nut                    | 6. Lock block            |
| 7. Telescopic lock guide     | 8. Bush spacer                 | 9. Tilt link assembly    |
| 10. Cooler                   | 11. Tilt unit assembly         | 12. Tilt sensor assembly |
| 13. Connector assembly       | 14. Clamp                      | 15. Spring               |
| 16. Telescopic unit assembly | 17. Telescopic sensor assembly |                          |

## Disassembly and Assembly

### DISASSEMBLY

AGS000HL

Disassemble the parts from jacket tube. The parts to be disassembled are shown in the figure.

### ASSEMBLY

- Refer to [PS-17, "Components \(with Automatic Drive Positioner\)"](#) for tightening torque. Install in the reverse order of disassembly.

# POWER STEERING GEAR AND LINKAGE

## POWER STEERING GEAR AND LINKAGE

PPF:49001

### Removal and Installation

AGS000H0

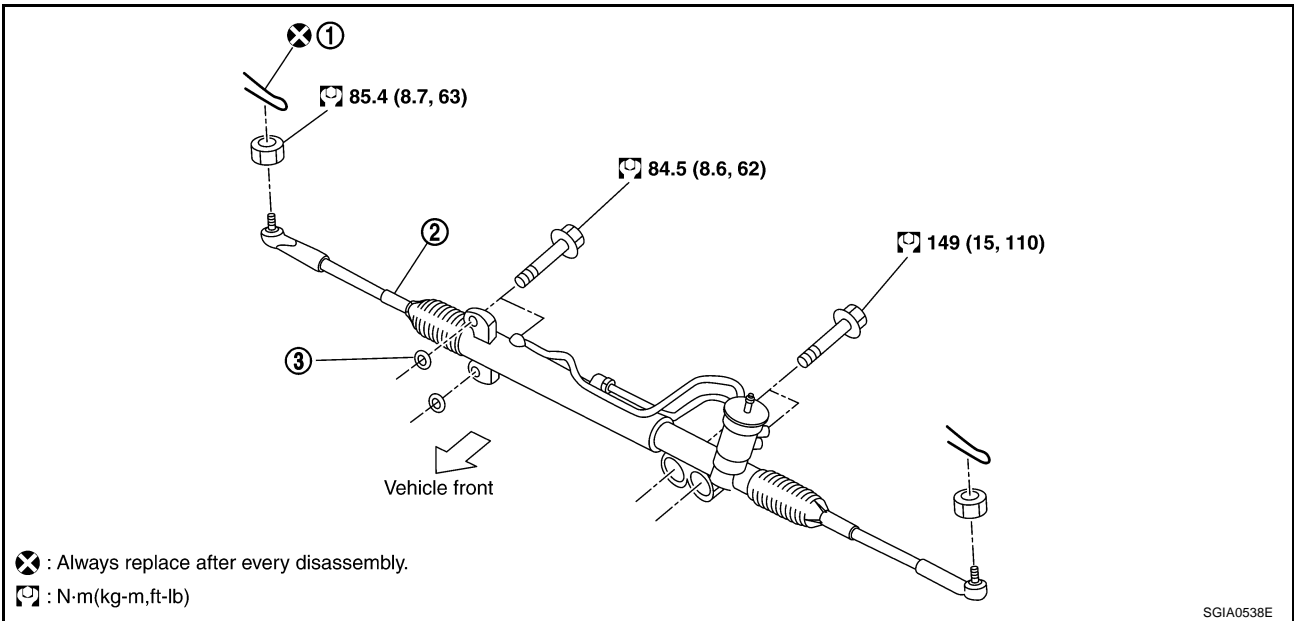

1. Cotter pin

2. Steering gear assembly

3. Washer

### CAUTION:

Spiral cable may snap due to steering operation if steering column is separated from steering gear assembly. Therefore fix steering wheel with a string to avoid turns.

### REMOVAL

1. Set wheels in the straight-ahead position.
2. Remove tires from vehicle with power tool.
3. Remove undercover with power tool.
4. Confirm slit of lower joint fits with the projection on rear cover cap, furthermore marking position on steering gear assembly nearly fits with the projection on rear cover cap.
5. Remove cotter pin at steering outer socket, then loosen mounting nut.

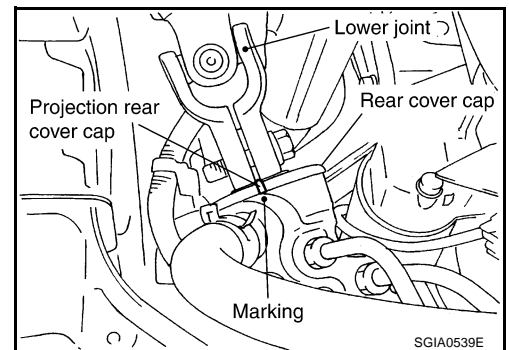

6. Use a ball joint remover (SST) to remove steering outer socket from steering knuckle. Be careful not to damage ball joint boot.

### CAUTION:

Tighten temporarily mounting nut to prevent damage to threads and to prevent ball joint remover (SST) from coming off.

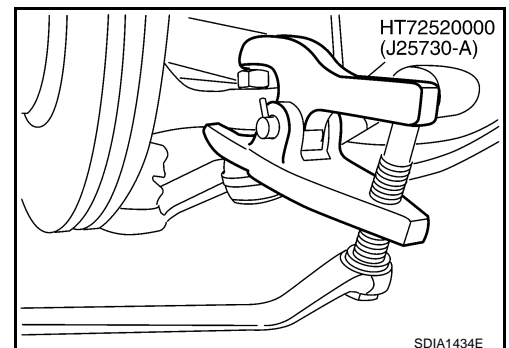

# POWER STEERING GEAR AND LINKAGE

7. Remove oil pipings (high pressure side and low pressure side) from steering gear assembly, then drain fluid from pipings.

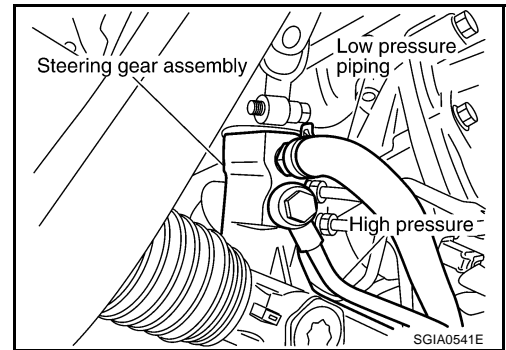

8. Remove mounting bolt of steering hydraulic piping bracket from steering gear assembly.

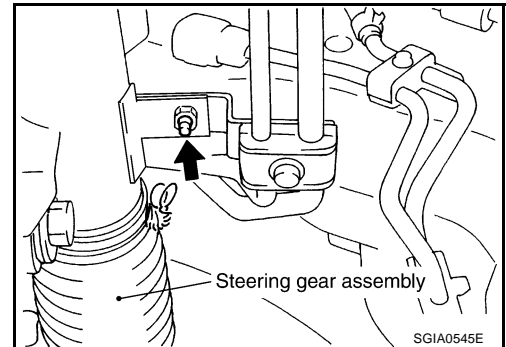

9. Remove mounting bolt (lower side) of lower joint.

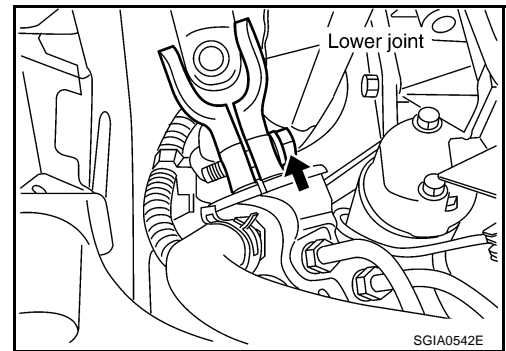

10. Remove mounting bolts of steering gear assembly with power tool, and then remove steering gear assembly from vehicle.

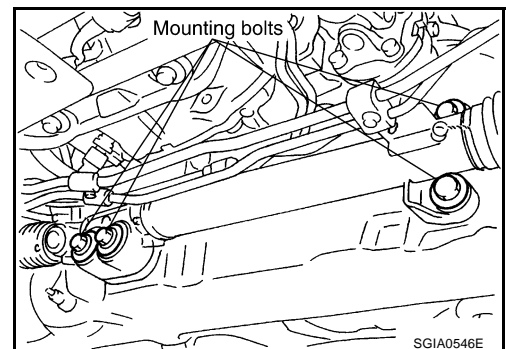

## INSTALLATION

- Refer to [PS-19, "Removal and Installation"](#) for tightening torque. Install in the reverse order of removal.

### NOTE:

Refer to component parts location and do not reuse non-reusable parts.

- After removing/installing or replacing steering components, check wheel alignment. Refer to [FSU-6, "Wheel Alignment Inspection"](#).
- After adjusting wheel alignment, adjust neutral position of steering angle sensor. Refer to [BRC-6, "Adjustment of Steering Angle Sensor Neutral Position"](#).

## POWER STEERING GEAR AND LINKAGE

- When steering wheel is set in the straight ahead direction, confirm slit of lower joint fits with the projection on rear cover cap, furthermore marking position on steering gear assembly nearly fits with the projection on rear cover cap.
- After installation, bleed air from piping. Refer to [PS-8, "Air Bleeding Hydraulic System"](#).

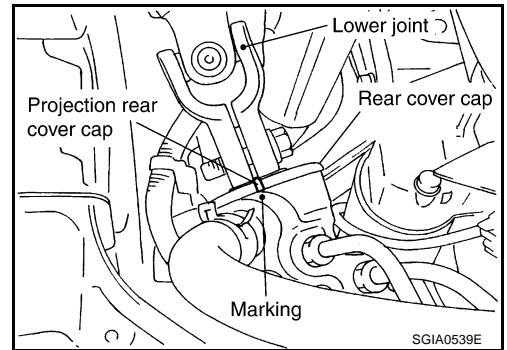

### INSPECTION AFTER INSTALLATION

Check if steering wheel turns smoothly when it is turned several times fully to the end of the left and right.

A  
B  
C  
D  
E  
F  
PS  
H  
I  
J  
K  
L  
M

# POWER STEERING GEAR AND LINKAGE

## Disassembly and Assembly

AGS000H1

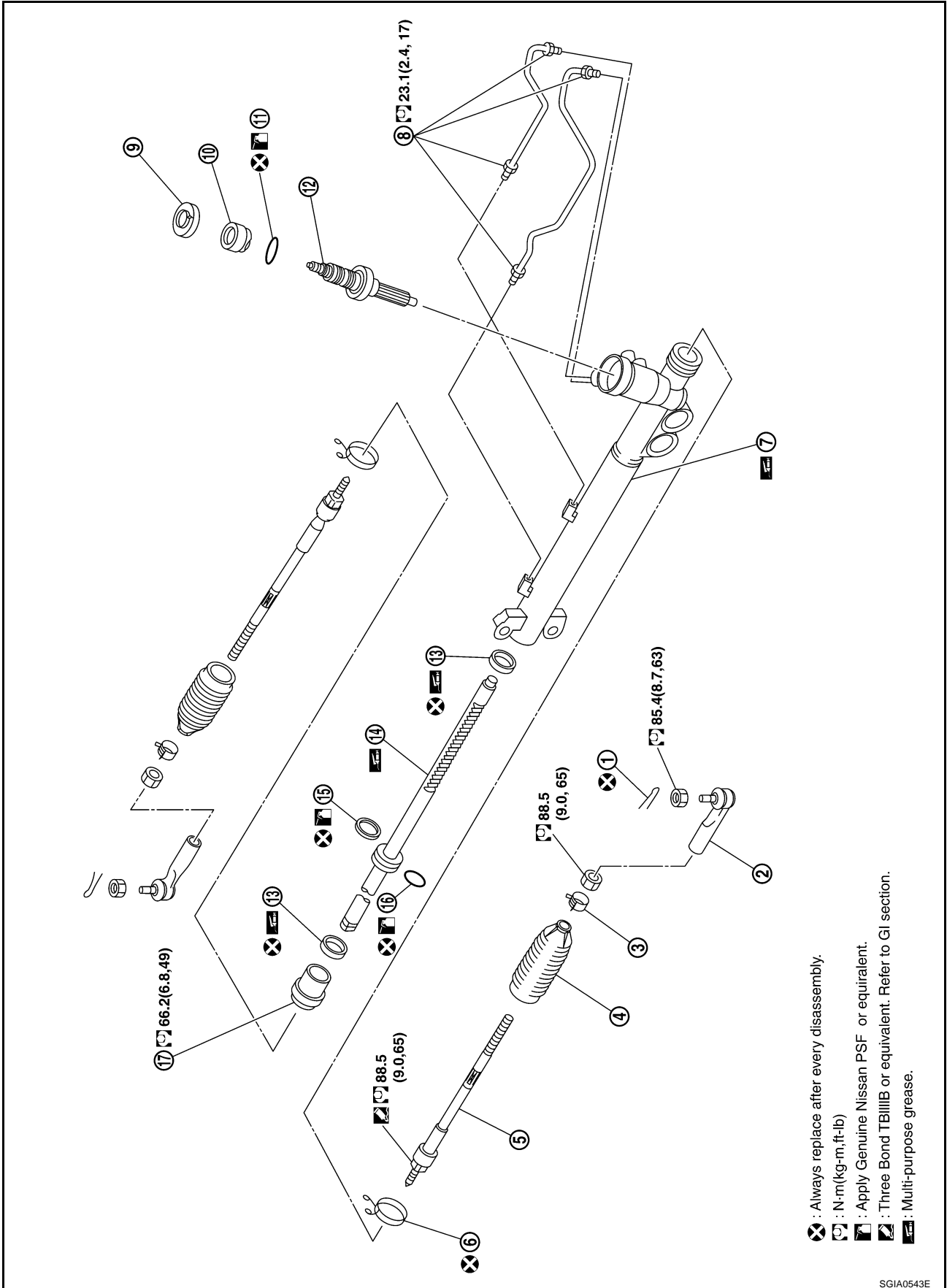

SGIA0543E

# POWER STEERING GEAR AND LINKAGE

- |                          |                        |                       |
|--------------------------|------------------------|-----------------------|
| 1. Cotter pin            | 2. Outer socket        | 3. Boot clamp         |
| 4. Boot                  | 5. Inner socket        | 6. Boot clamp         |
| 7. Gear housing assembly | 8. Cylinder tubes      | 9. Rear cover cap     |
| 10. Rear cover           | 11. O-ring             | 12. Sub-gear assembly |
| 13. Rack oil seal        | 14. Rack assembly      | 15. Rack Teflon ring  |
| 16. O-ring               | 17. End cover assembly |                       |

## CAUTION:

- Secure steering gear assembly with a vise, using copper plates or something similar to prevent it from being damaged. Do not grip cylinder with a vise.
- Before performing disassembly, clean steering gear assembly with kerosene. Be careful not to bring any kerosene into contact with the discharge and return port connectors.

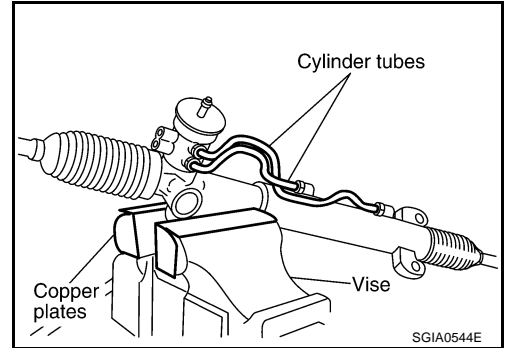

## DISASSEMBLY

1. Remove cylinder tubes from gear housing assembly.
2. Remove rear cover cap from gear housing assembly.
3. Measure adjusting screw height from gear housing assembly, then loosen adjusting screw.

## CAUTION:

- Do not turn adjusting screw more than twice.
- Replace steering gear assembly when adjusting screw is removed or more than twice.

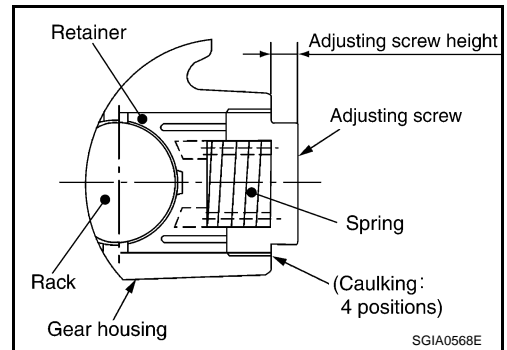

4. Use a rear cover wrench (SST) to remove rear cover from sub-gear assembly.

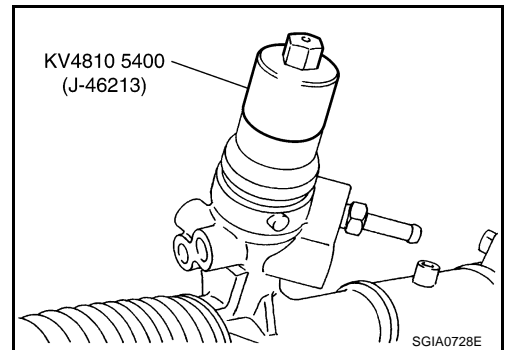

5. Remove O-ring with a flat-bladed screwdriver, and pull out rear cover.
6. Remove sub-gear assembly from gear housing assembly.

## CAUTION:

**In order to protect oil seal from any damage, pull sub-gear assembly out straightly.**

7. Loosen lock nut of outer socket, and remove outer socket.
8. Remove boot clamps of the small diameter side and the large diameter side, then remove boot.

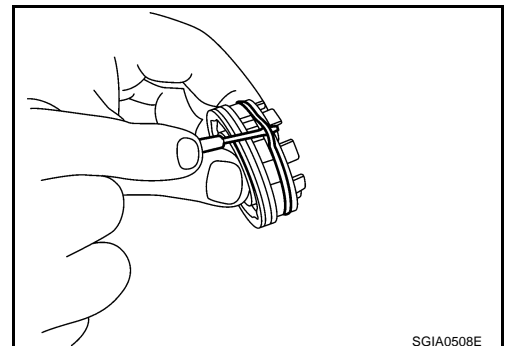

A  
B  
C  
D  
E  
F  
PS  
H  
I  
J  
K  
L  
M

## POWER STEERING GEAR AND LINKAGE

### CAUTION:

When removing boots, be careful not to damage inner socket and gear housing assembly. If they are damaged, change them to avoid oil leaks.

9. Drill out the clinching part of cylinder outer rim with a 3 mm (0.12 in) drill in 1.5 mm (0.059 in) depth.

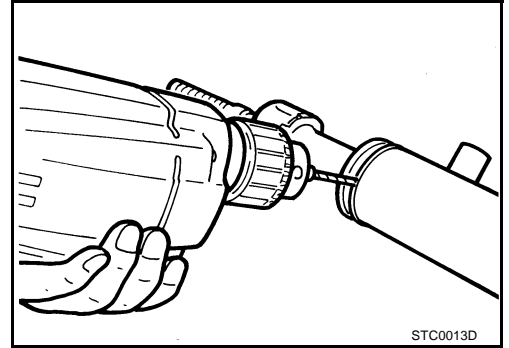

10. Remove end cover assembly with a 45 mm (1.77 in) open head (suitable tool).

### CAUTION:

Be careful not to damage rack. If it is damaged, replace rack. Otherwise, oil leaks may result.

11. Pull rack assembly with rack oil seal out of gear housing assembly.

### CAUTION:

Be careful not to damage cylinder. If it is damaged, replace gear housing assembly. Otherwise, oil leaks may result.

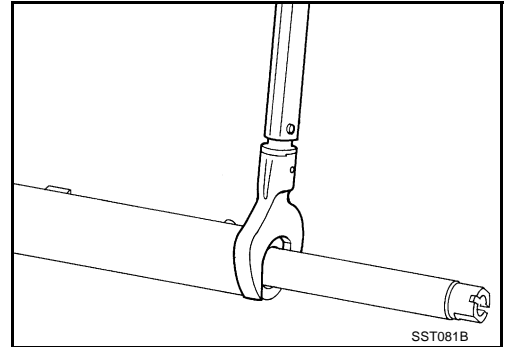

12. Heat rack Teflon ring to approximately 40°C (104°F) with a dryer, then remove it and O-ring from rack.

### CAUTION:

Be careful not to damage rack. If it is damaged, change to a new one to avoid oil leaks.

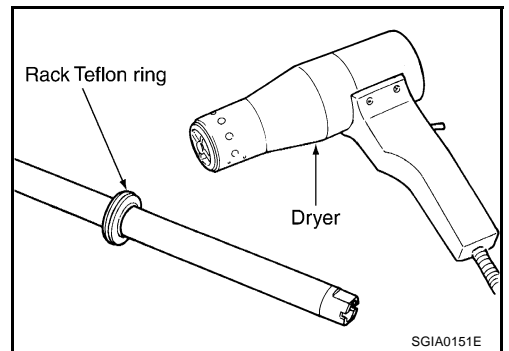

13. Use a taped 29 mm (1.14 in) socket and an extension bar. Remove rack oil seal from gear housing assembly.

### CAUTION:

Be careful not to damage gear housing assembly and cylinder inner wall. If it is damaged, gear housing assembly must be replaced. Otherwise, oil leaks will result.

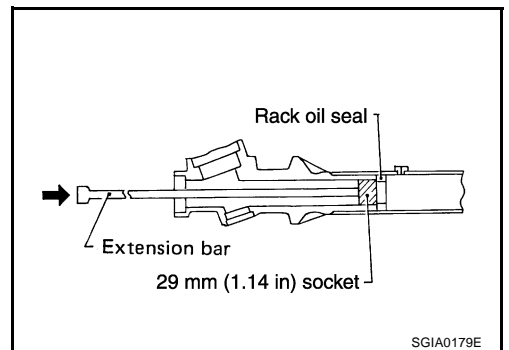



# POWER STEERING GEAR AND LINKAGE

## INSPECTION AFTER DISASSEMBLY

### Boot

Check boot for cracks and deformation. Replace it, if necessary.

### Rack

Check rack for damage and wear. Replace it, if necessary.

### Sub-Gear Assembly

- Check pinion gear for damage and wear. Replace it, if necessary.
- Check bearing while rotating it. Replace bearing if bearing ball race was dented, worn, or damaged.

### Gear Housing Assembly

Check gear housing assembly for damage and scratches (inner wall). Replace it, if necessary.

### Outer Socket and Inner Socket

#### Swing Torque

- Hook a spring balance at the point shown in the figure. Confirm if the reading is within the specification. When ball stud and inner socket start moving the measured value must be within the specification. If the reading is outside the specification, replace socket.

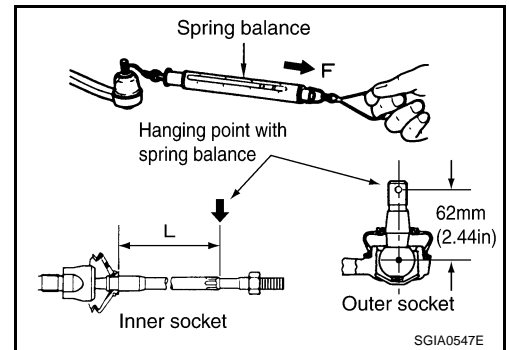

Item	Outer socket	Inner socket
Measuring point	Cotter pin hole of stud	Shown as L: 83.2 mm (3.276 in)
Swing torque	0.3 – 2.9 N·m (0.03 – 0.29 kg·m, 3 – 25 in·lb)	1.0 – 7.8 N·m (0.11 – 0.79 kg·m, 9 – 69 in·lb)
Measuring value	4.84 – 46.7 N (0.50 – 4.7 kg, 4 – 34 lb)	12.1 – 93.7 N (1.3 – 9.5 kg, 9 – 69 lb)

#### Rotating Torque

- Using a preload gauge (SST), check if reading is within the value specified below. If the value is outside the standard, replace outer sockets.

Rotating torque	0.3 – 2.9 N·m (0.03 – 0.29 kg·m, 3 – 25 in·lb)
-----------------	--

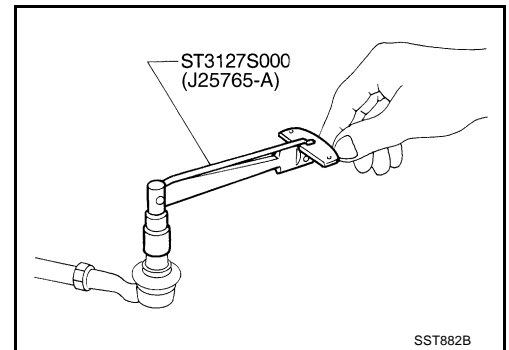

# POWER STEERING GEAR AND LINKAGE

## Axial End Play

- Apply load of 490 N (50 kg, 110 lb) to ball stud axially. Use a dial gauge to measure the amount of the movement that the stud makes. Check if the reading is within the specified below. If the value is outside the standard, replace outer and inner sockets.

Outer socket	0.5 mm (0.020 in) or less
Inner socket	0.2 mm (0.008 in) or less

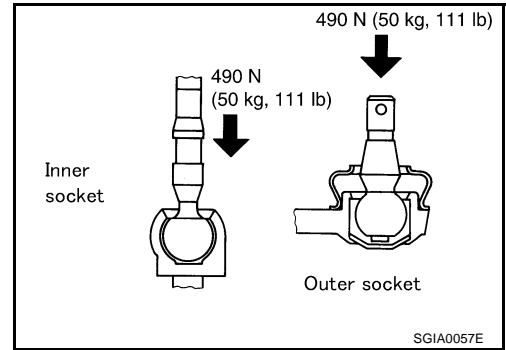

## ASSEMBLY

- Apply Genuine Nissan PSF or equivalent to O-ring. Put an O-ring into rack Teflon ring.

**NOTE:**

Do not reuse O-ring.

- Heat rack Teflon ring to approximately 40°C (104°F) with a dryer. Assemble it to mounting groove of rack.

**NOTE:**

Do not reuse rack Teflon ring.

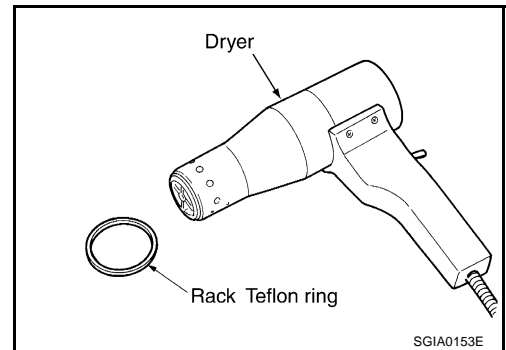

- To fit rack Teflon ring on rack, use rack Teflon ring installation tool (SST) from tooth side. Compress rim of ring with the tool.

- Apply Multi-purpose grease to rack oil seal. Insert rack oil seal, then insert rack assembly to gear housing assembly.

**NOTE:**

Do not reuse rack oil seal.

**CAUTION:**

- When inserting rack assembly, do not damage retainer sliding part. If it is damaged, replace gear housing assembly.
- When inserting rack assembly, do not damage cylinder inner wall. If it is damaged, it may cause oil leaks. Replace gear housing assembly.
- Attach rack oil seal. Both inner lip and outer lip should face each other.

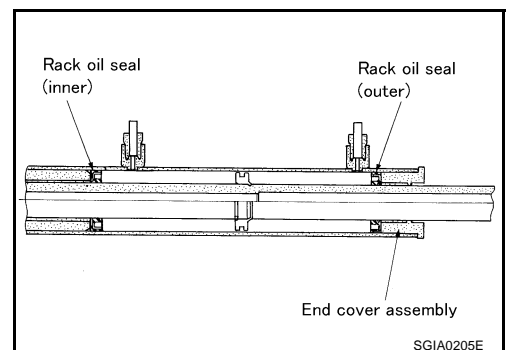
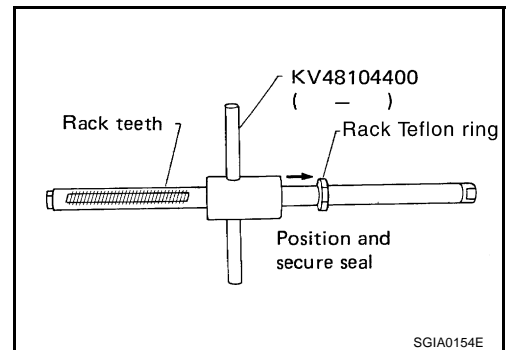

# POWER STEERING GEAR AND LINKAGE

- a. To avoid damaging inner rack oil seal, wrap an OHP sheet [approximately. 70 mm (2.76 in) × 100 mm (3.94 in)] around rack tooth. Place oil seal on sheet. Then, pull oil seal along with OHP sheet until they pass the toothed section of rack, then remove it.

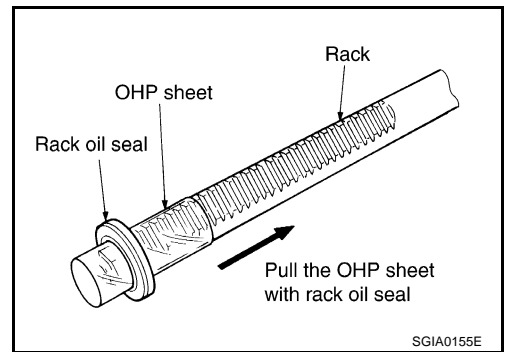

- b. Insert rack oil seal (inner) to piston (rack Teflon ring) position and push retainer to adjust screw side with fingers lightly, and then make rack move in gear housing assembly, install rack oil seal (inner) to fit with gear housing assembly.

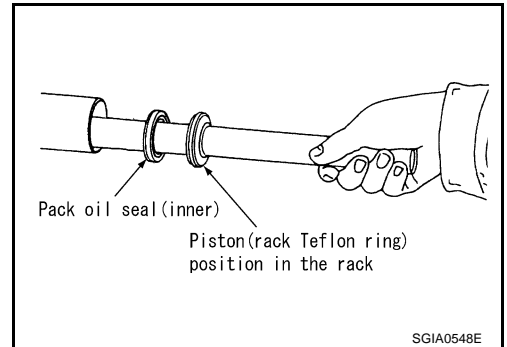

- c. When installing outer rack oil seal, cover the end of rack with an OHP sheet [70 mm (2.76 in) × 100 mm (3.94 in)]. It will avoid damaging rack oil seal. Then place oil seal on sheet. Pull rack oil seal along with OHP sheet until they pass rack end. Then remove OHP sheet.

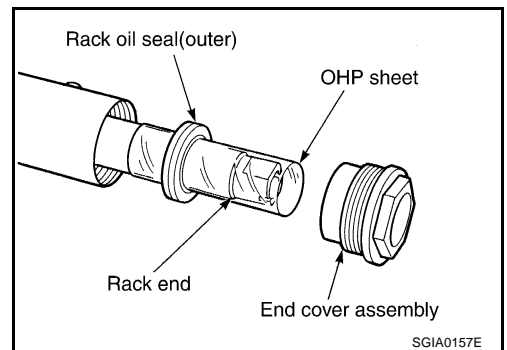

- d. Install end cover assembly to rack, move it to gear housing assembly.

5. Using a 45 mm (1.77 in) open head (suitable tool), tighten end cover assembly at the specified torque.

**CAUTION:**

**Do not damage rack surface. If it is damaged, it may cause oil leaks. Replace rack assembly.**

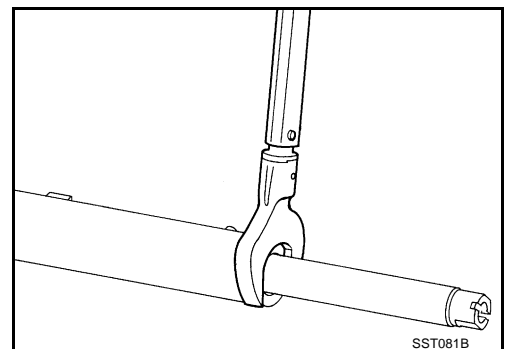

6. After tightening end cover assembly, caulk cylinder at one point as shown in the figure using a punch. This will prevent end cover from getting loose.

7. Install sub-gear assembly to gear housing assembly.

**CAUTION:**

**In order to protect oil seal from any damage, insert sub-gear assembly out straightly.**

8. Apply Genuine Nissan PSF or equivalent to O-ring. Install O-ring to rear cover.

**NOTE:**

Do not reuse O-ring.

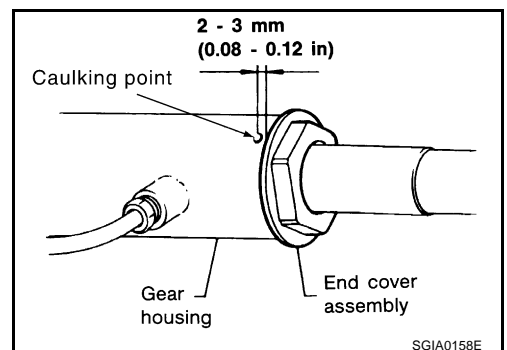

A  
B  
C  
D  
E  
F  
PS  
H  
I  
J  
K  
L  
M

# POWER STEERING GEAR AND LINKAGE

9. Use a rear cover wrench (SST), install rear cover to gear housing assembly.
10. Confirm projection on rear cover cap nearly fit with marking position on gear housing assembly.
11. Apply thread locking adhesive (Three Bound TB1111B or equivalent. Refer to [GI-48](#) ) to the thread of adjusting screw to the adjusting screw height from gear housing assembly. The adjusting screw height is the same as it was measured in the overhaul in advance.
12. Rotate pinion ten times whole range of rack so that parts get to fit with each other.

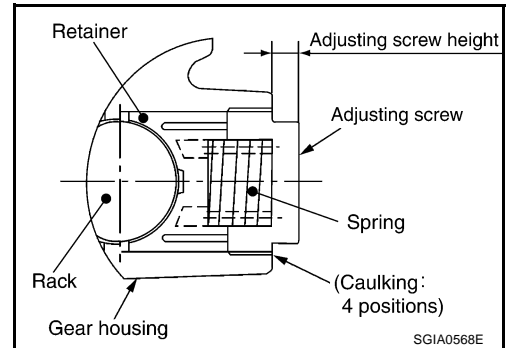

13. Measure pinion rotating torque within from  $-180^\circ$  to  $+180^\circ$ , make preload gauge (SST) and torque adapter (SST) in rack neutral position, then hold preload gauge (SST) at maximum torque.
14. After loosening adjusting screw once, tighten it again with torque of 5.4 N·m (0.55 kg·m, 48 in·lb). After that loosen it within  $20^\circ$  to  $40^\circ$ .

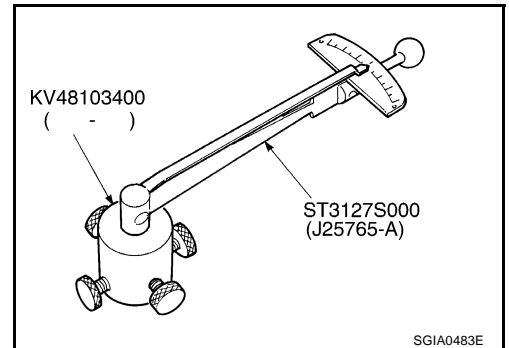

15. Measure pinion rotating torque with torque adapter (SST) and preload gauge (SST), then confirm whether it's reading is within the specified value. If the reading is not within the specified value, readjust screw angle with adjusting screw. Change gear assembly to new one, if the reading is still not within the specified value or the rotating torque of adjusting screw is less than 5 N·m (0.51 kg·m, 44 in·lb).

**Pinion rotating torque:**

**Around neutral position (within  $\pm 100^\circ$ )**

**Average "A":**

**0.8 – 2.0 N·m (0.09 – 0.20 kg·m, 7 – 17 in·lb)**

**Other than above (more than  $\pm 100^\circ$ )**

**Maximum variation "B":**

**2.3 N·m (0.23 kg·m, 20 in·lb)**

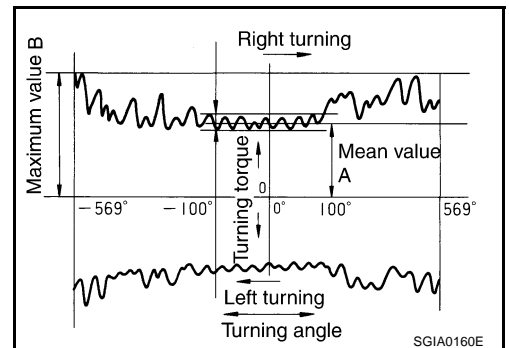

16. Turn pinion fully to the end of the left with inner socket to gear housing assembly.
17. Set dial gauge to rack as shown in the figure. Measure vertical movement of rack when pinion is turned counterclockwise with torque of 19.6 N·m (2.0 kg·m, 14 ft·lb). Check reading is within the specified value. If reading is outside of the specification, readjust screw angle with adjusting screw. If reading is still outside of specification, or if the rotating torque of adjusting screw is less than 5 N·m (0.51 kg·m, 44 in·lb), replace steering gear assembly.

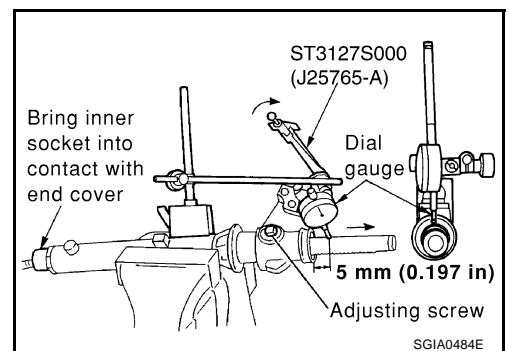

# POWER STEERING GEAR AND LINKAGE

<b>Amount of vertical movement with rack</b>	<b>Less than 0.265 mm (0.010 in)</b>	
<b>Measuring point</b>	<b>Axial direction of rack</b>	<b>5 mm (0.197 in) away from end of gear housing</b>
	<b>Radius direction of rack</b>	<b>Shaft direction of adjusting screw</b>

18. Install large-diameter side of boot to gear housing assembly.
19. Install small-diameter side of boot to the mounting groove of inner socket boot.
20. Install boot clamp to the small-diameter side of boot.
21. Install boot clamp to the large-diameter side of boot.

**NOTE:**

Do not reuse boot clamp.

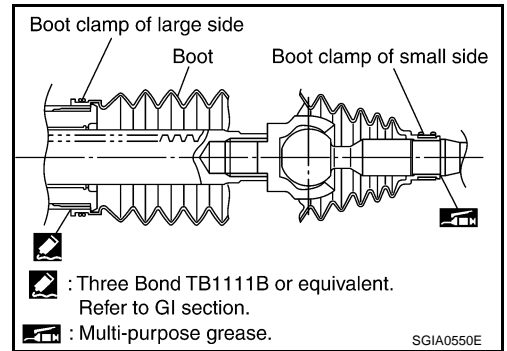

- a. Tighten large-diameter side of RH/LH boot with boot clamp (stainless wire).

**Wire length "L" : 390 mm (15.35 in)**

- b. After wrapping clamp around boot groove for two turns, insert screwdriver in loop on both ends of wire. Twist 4 to 4.5 turns while pulling with a force of approx. 98 N (10 kg, 22.1 lb).

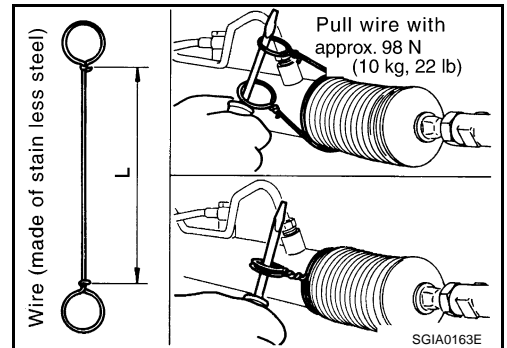

- c. Twist boot clamp as shown in the figure, pay attention to relationship between winding and twisting directions.

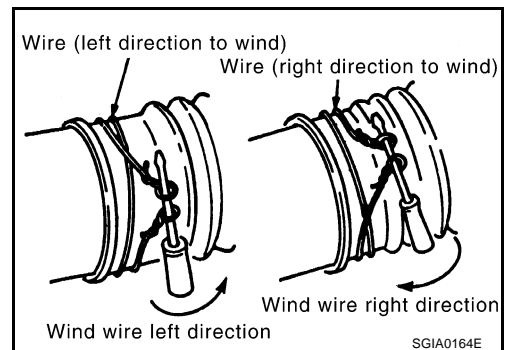

22. Install cylinder tubes to gear housing assembly.
23. Install lock nut and outer socket to inner socket.

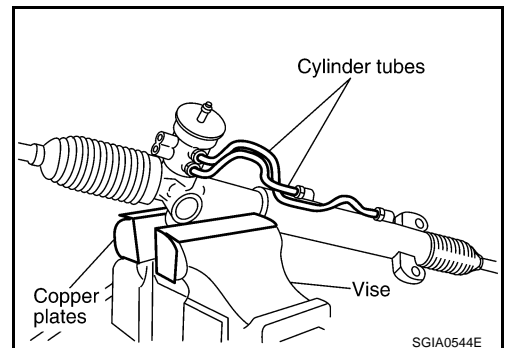

## POWER STEERING GEAR AND LINKAGE

24. Tighten lightly inner socket in specified length "L", then tighten lock nut at specified torque. Refer to [PS-22, "Disassembly and Assembly"](#) . Reconfirm if inner socket length is within limit of specified length "L".

**Inner socket length "L" : 135.2 mm (5.32 in)**

**CAUTION:**

Perform toe-in adjustment after this procedure. Length achieved after toe-in adjustment is not necessary value given here.

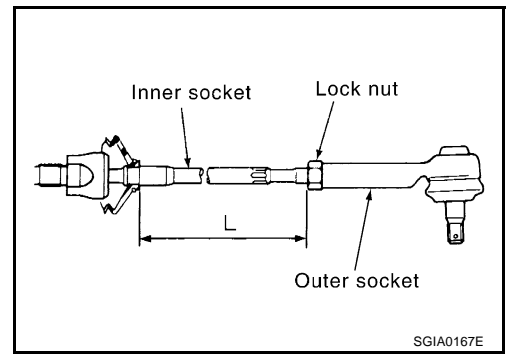

# POWER STEERING OIL PUMP

## POWER STEERING OIL PUMP

PF:49110

### On-Vehicle Inspection and Service CHECKING RELIEF OIL PRESSURE (VQ35DE MODELS)

AGS000H2

**CAUTION:**

Before starting work, confirm belt tension is proper.

1. Connect oil pressure gauge (SST) and oil pressure gauge adapter (SST) between oil pump discharge connector and high pressure hose and then bleed air from the hydraulic circuit.

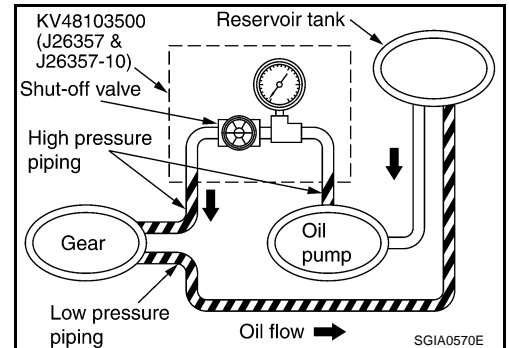

SST		
Pressure gauge		KV48103500 (J26357&J26357-10)
Oil pump side	Eye joint	KV48102500-01 ( — )
	Washer	KV48102500-04 ( — )
	Bolt	KV48102500-03 ( — )
High pressure piping side	Flare joint	KV48102500-02 ( — )
	Washer	KV48102500-04 ( — )
	Bolt	KV48102500-03 ( — )

2. Start engine. Allow engine to run until tank temperature reaches 50 to 80°C (122 to 176°F).

**CAUTION:**

- Warm up engine with shut-off valve fully opened. If engine is started with shut-off valve closed, fluid pressure in power steering pump increases to maximum. This will raise fluid temperature excessively.
- Be careful not to contact hose with belt when engine is started.

3. With engine at idle, close shut-off valve and read the relief oil pressure.

**Relief oil pressure:**

**9,900 - 10,700 kPa (101 - 109 kg/cm<sup>2</sup> , 1449 - 1564 psi)**

**CAUTION:**

**Do not close shut-off valve of pressure gauge for more than 10 seconds.**

4. After measurement, open shut-off valve slowly.  
If relief oil pressure is outside the specification, disassemble and repair oil pump. Refer to [PS-33, "Disassembly and Assembly \(VQ35DE Models\)"](#) .
5. After inspection, disconnect oil pressure gauge (SST) and oil pressure gauge adapter (SST) from hydraulic circuit, connect oil pump discharge connector and high pressure hose. Add fluid and bleed air from hydraulic circuit thoroughly.  
Refer to [PS-8, "Air Bleeding Hydraulic System"](#) .

### CHECKING RELIEF OIL PRESSURE (VK45DE MODELS)

**CAUTION:**

Before starting work, confirm belt tension is proper.

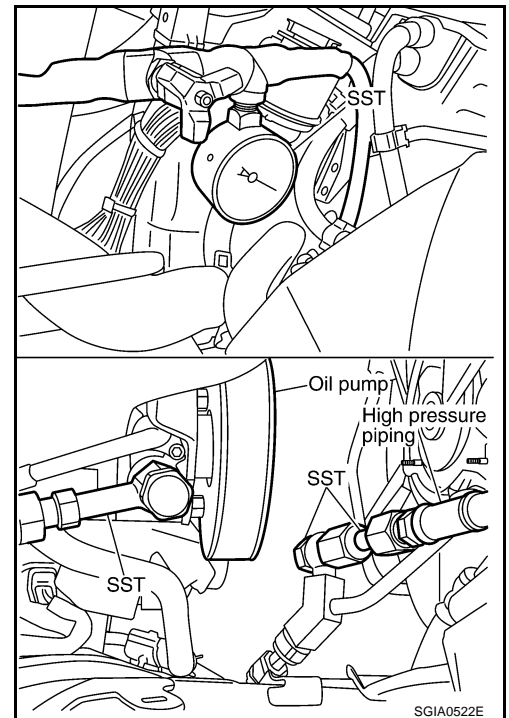

# POWER STEERING OIL PUMP

1. Connect oil pressure gauge (SST) and oil pressure gauge adapter (SST) between oil pump discharge connector and high pressure hose and then bleed air from the hydraulic circuit.

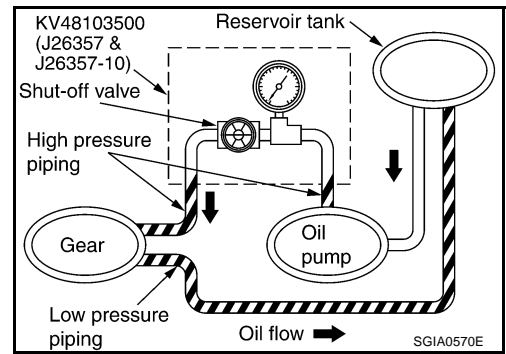

## SST

Pressure gauge and shut-off valve		KV48103500 (J26357 and J26357-10)
Oil pump side	Connector A and O-ring	KV48105300-4 and 5295262U10 ( — )
	Eye-bolt and O-ring	KV48105300-3 and 5295262U00 ( — )
High pressure piping side	Connector B and O-ring	KV48105300-1 and 5295262U00 ( — )
	Nut	KV48105300-2 ( — )

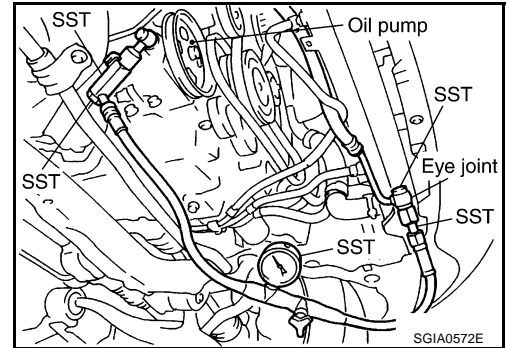

2. Start engine. Allow engine to run until tank temperature reaches 50 to 80°C (122 to 176°F).

### CAUTION:

- Warm up engine with shut-off valve fully opened. If engine is started with shut-off valve closed, fluid pressure in power steering pump increases to maximum. This will raise fluid temperature excessively.
- Be careful not to contact hose with belt when engine is started.

3. With engine at idle, close shut-off valve and read the relief oil pressure.

### Relief oil pressure:

9,900 - 10,700 kPa (101 - 109 kg/cm<sup>2</sup> , 1449 - 1564 psi)

### CAUTION:

Do not close shut-off valve of pressure gauge for more than 10 seconds.

4. After measurement, open shut-off valve slowly.  
If relief oil pressure is outside the specification, disassemble and repair oil pump. Refer to [PS-37, "Disassembly and Assembly \(VK45DE Models\)"](#).
5. After inspection, disconnect oil pressure gauge (SST) and oil pressure gauge adapter (SST) from hydraulic circuit, connect oil pump discharge connector and high pressure hose. Add fluid and bleed air from hydraulic circuit thoroughly. Refer to [PS-8, "Air Bleeding Hydraulic System"](#).

## Removal and Installation (VQ35DE Models)

### REMOVAL

1. Remove undercover from vehicle with power tool.
2. Loosen belt tensioner adjust screw, then remove belt from oil pump pulley. Refer to [EM-15, "DRIVE BELTS"](#).
3. Drain power steering fluid from reservoir tank.

AGS000HI



# POWER STEERING OIL PUMP

4. Remove piping of high pressure and low pressure (drain fluid from their pipings). Refer to [PS-41, "HYDRAULIC LINE"](#).
5. Remove mounting bolts, then remove power steering pump.

## INSTALLATION

Refer to [PS-41, "HYDRAULIC LINE"](#) for tightening torque. Install in the reverse order removal.

- After installation, adjust belt tension. Refer to [EM-15, "DRIVE BELTS"](#).
- After installation, bleed air. Refer to [PS-8, "Air Bleeding Hydraulic System"](#).

## Removal and Installation (VK45DE Models)

AGS000HJ

### REMOVAL

1. Remove undercover from vehicle with power tool.
2. Remove power steering oil pump belt from auto tensioner. Refer to [EM-167, "DRIVE BELTS"](#).
3. Drain power steering fluid from reservoir tank.
4. Remove piping of high pressure and low pressure from power steering oil pump (drain fluid from their pipings). Refer to [PS-41, "HYDRAULIC LINE"](#).
5. Remove mounting bolts, then remove power steering pump.

### INSTALLATION

Refer to [PS-41, "HYDRAULIC LINE"](#) for tightening torque. Install in the reverse order removal. After installation, bleed air. Refer to [PS-8, "Air Bleeding Hydraulic System"](#).

#### NOTE:

Adjustment of belt tension is no necessary because engine of this model equips auto tensioner.

## Disassembly and Assembly (VQ35DE Models)

AGS000HE

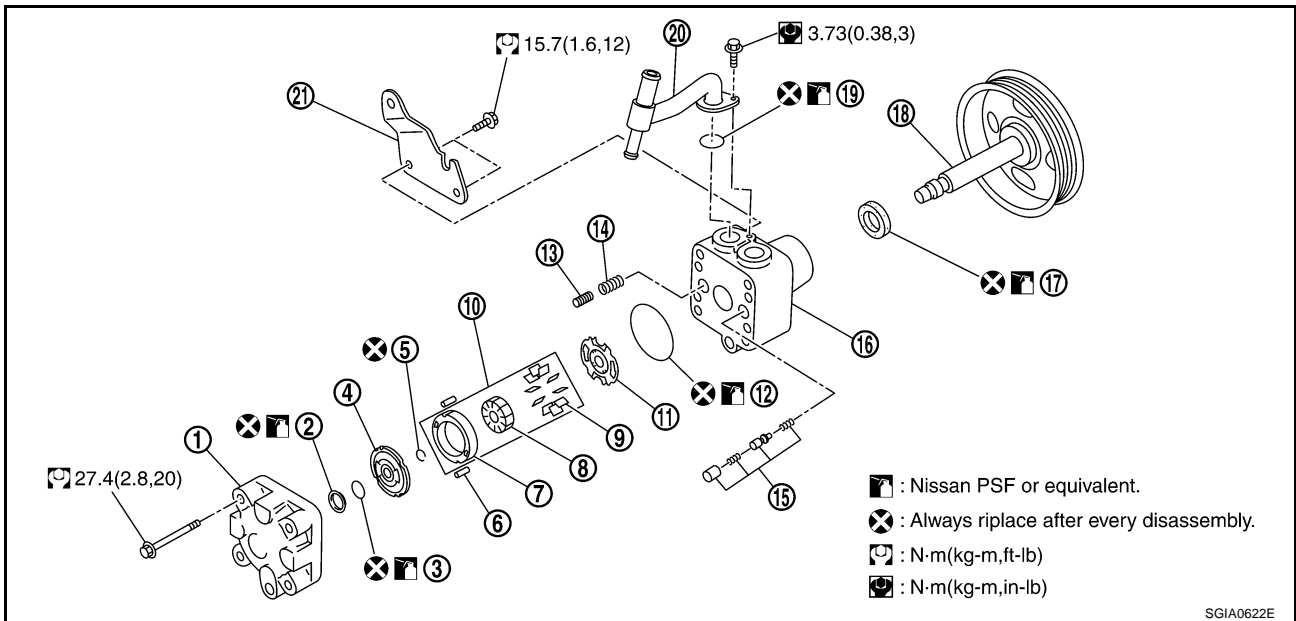

SGIA0622E

- |                          |                      |                                   |
|--------------------------|----------------------|-----------------------------------|
| 1. Rear cover            | 2. Teflon ring       | 3. O-ring                         |
| 4. Rear side plate       | 5. Rotor snap ring   | 6. Dowel pin                      |
| 7. Cam ring              | 8. Rotor             | 9. Vane                           |
| 10. Cartridge            | 11. Front side plate | 12. O-ring                        |
| 13. Flow control valve A | 14. Spring           | 15. Flow control valve B assembly |
| 16. Body assembly        | 17. Oil seal         | 18. Pulley                        |
| 19. O-ring               | 20. Suction pipe     | 21. Bracket                       |

## INSPECTION BEFORE DISASSEMBLY

Disassemble power steering oil pump only if the following items are found.

- Oil leakage from oil pump
- Deformed or damaged pulley

# POWER STEERING OIL PUMP

- Poor performance

## DISASSEMBLY

### NOTE:

Fix oil pump in vise as the occasion demands.

### CAUTION:

**When retaining drive shaft in a vise, always use copper or aluminum plates between vise and shaft.**

1. Unscrew four rear cover bolts and remove rear cover from body assembly.
2. Remove rear side plate from cartridge, then remove Teflon ring and O-ring from rear side plate.
3. Remove rotor snap ring with snap ring pliers, and remove pulley from body assembly.

### CAUTION:

**When removing rotor snap ring, be careful not to damage pulley shaft.**

4. Remove oil seal from body assembly.

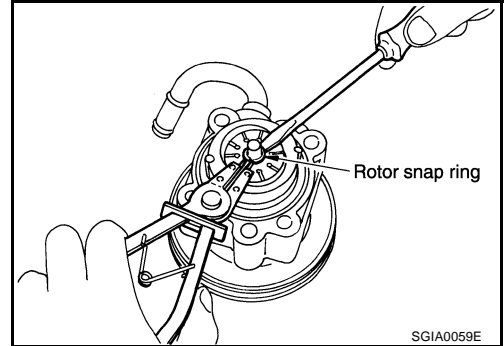

5. Remove cam ring, rotor, vane, front side plate, flow control valve A, spring, flow control valve B assembly and O-ring from body assembly.

### CAUTION:

**Be careful not to drop and deform flow control valve A and flow control valve B assembly.**

6. Remove suction pipe from body assembly.
7. Remove O-ring from suction pipe.
8. Remove bracket from body assembly.

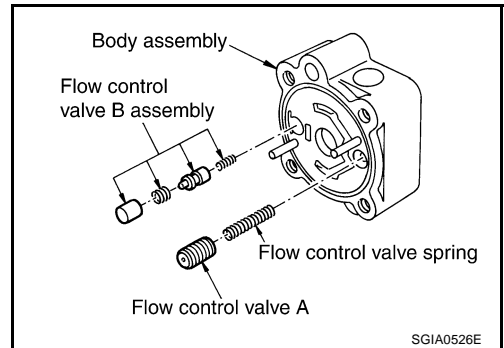

## INSPECTION AFTER DISASSEMBLY

### Body Assembly and Rear Cover Inspection

Check body assembly and the inside of rear cover for damage. If any damage is found, replace with new part for rear cover, and replace with new power steering pump assembly for body assembly.

### Cartridge Assembly Inspection

Check cam ring, side plate, rotor and vane for damage. If any damage is found, replace cartridge assembly with new one.

# POWER STEERING OIL PUMP

## ASSEMBLY

### NOTE:

Fix oil pump in vise as occasion demands.

### CAUTION:

**When retaining drive shaft in a vise, always use copper or aluminum plates between vise and shaft.**

1. Apply Genuine Nissan PSF or equivalent to oil seal lip and to the circumference of oil seal. Using a drift (SST), install oil seal to body assembly.

### NOTE:

Do not reuse oil seal.

2. If dowel pin has been removed, insert it into body assembly by hand. If it cannot be inserted by hand, lightly tap with a hammer.

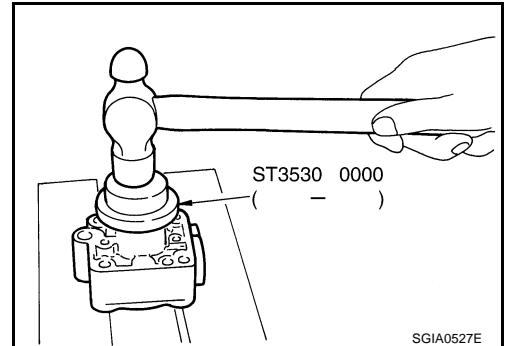

3. Install flow control valve A, flow control valve spring and flow control valve B assembly to locations shown in the figure.

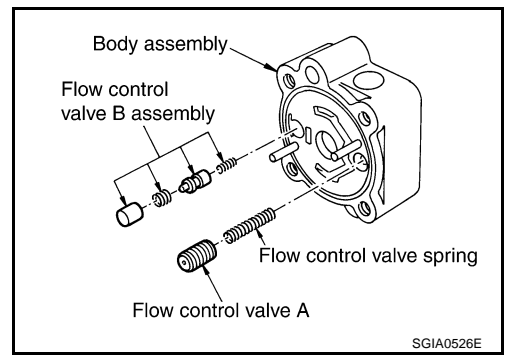

4. Match dowel pin A on flow control valve A, shown in the figure, with cutout B of front side plate and then install front side plate to body assembly.

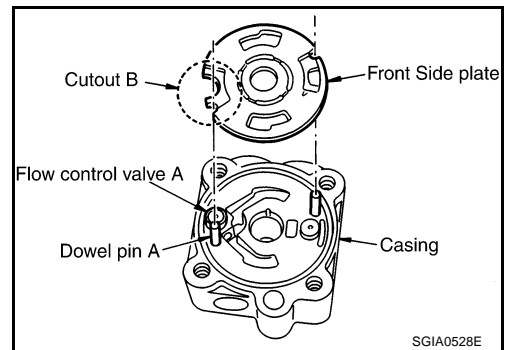

A  
B  
C  
D  
E  
F  
PS  
H  
I  
J  
K  
L  
M

# POWER STEERING OIL PUMP

5. Install cam ring onto front side plate with smaller slit of cam ring facing body assembly.
6. Install pulley to body assembly.

**CAUTION:**

When installing pulley, be careful not to scratch oil seal.

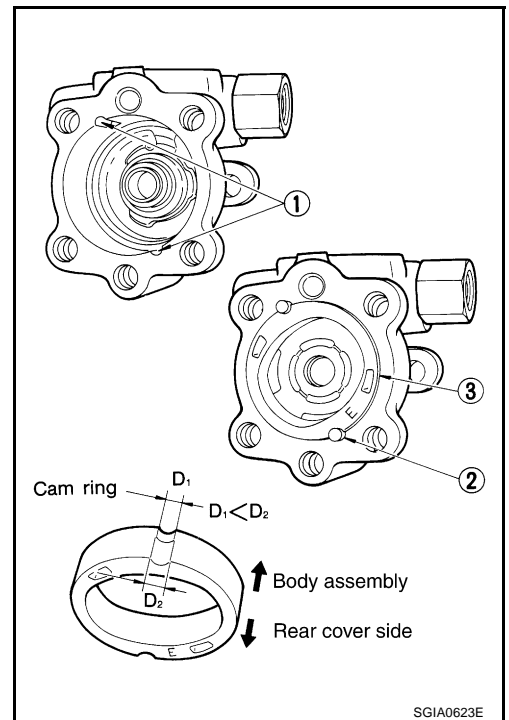

7. Face the side of rotor with punch mark towards rear cover, and attach rotor to pulley shaft.

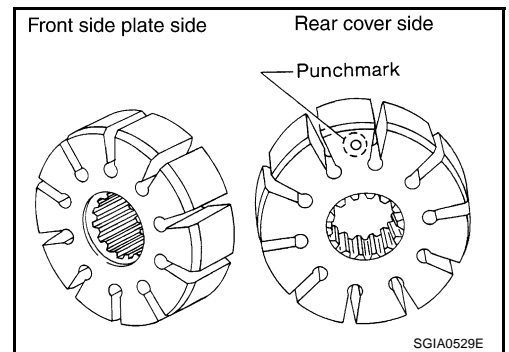

8. Install vane to rotor with facing the round portion outside.

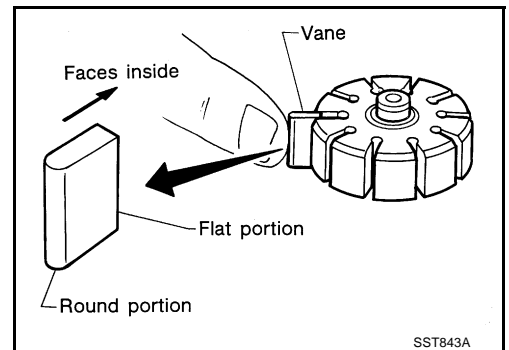

9. Using a hammer and a 10 mm (0.39 in) box, install rotor snap ring to slot in pulley shaft.

**NOTE:**

Do not reuse snap ring.

**CAUTION:**

Be careful not to damage rotor and pulley shaft.

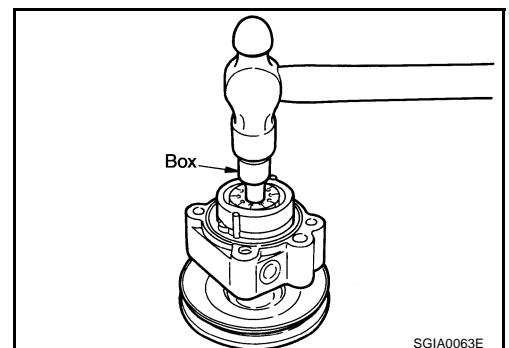

# POWER STEERING OIL PUMP

10. Match dowel pin A on flow control valve A, shown in the figure, with cutout B of rear side plate and install rear side plate to cartridge.

11. Apply Genuine Nissan PSF or equivalent to O-ring and install O-ring into rear side plate.

**NOTE:**

Do not reuse O-ring.

12. Apply Genuine Nissan PSF or equivalent to Teflon ring and install Teflon ring into rear side plate.

**NOTE:**

Do not reuse Teflon ring.

13. Position rear cover on body assembly and tighten mounting bolts to specified torque.

14. Apply Genuine Nissan PSF or equivalent to O-ring and install O-ring into suction pipe.

**NOTE:**

Do not reuse O-ring.

15. Install suction pipe into body assembly.

16. Install bracket to body assembly and tighten mounting bolts to specified torque.

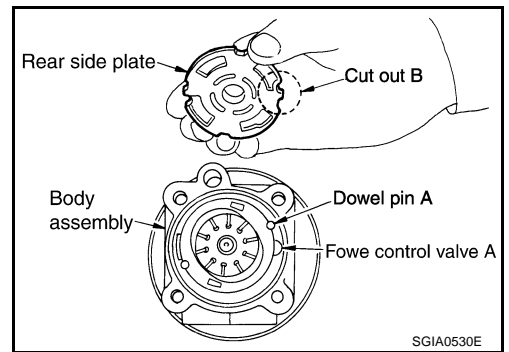

## Disassembly and Assembly (VK45DE Models)

AGS000H4

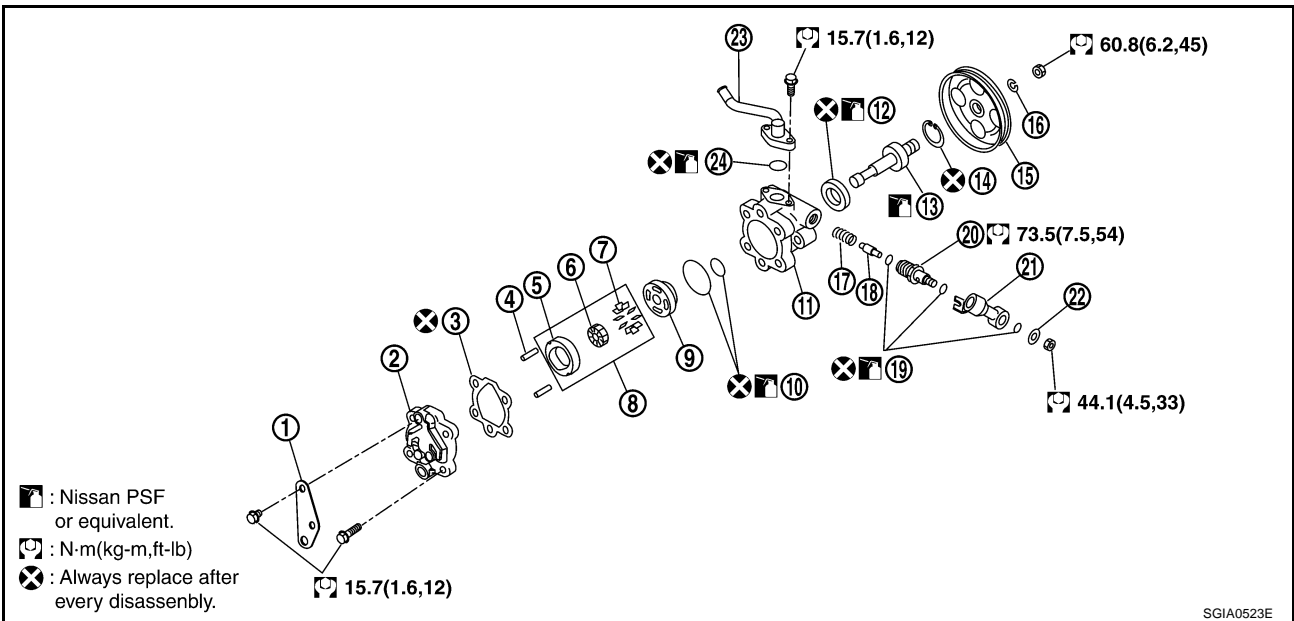

- |                          |                    |                        |
|--------------------------|--------------------|------------------------|
| 1. Bracket               | 2. Rear cover      | 3. Gasket              |
| 4. Lock pin              | 5. Cam ring        | 6. Rotor               |
| 7. Vane                  | 8. Cartridge       | 9. Side plate          |
| 10. O-ring               | 11. Body assembly  | 12. Oil seal           |
| 13. Drive shaft assembly | 14. Snap ring      | 15. Pulley             |
| 16. Spring washer        | 17. Spring         | 18. Flow control valve |
| 19. O-ring               | 20. Connector bolt | 21. Joint              |
| 22. Washer               | 23. Suction pipe   | 24. O-ring             |

## INSPECTION BEFORE DISASSEMBLY

Disassemble power steering oil pump only if the following items are found.

- Oil leakage from oil pump.
- Deformed or damaged pulley
- Poor performance

# POWER STEERING OIL PUMP

## DISASSEMBLY

### NOTE:

Fix oil pump in vise as the occasion demands.

### CAUTION:

**When retaining drive shaft in a vise, always use copper or aluminum plates between vise and shaft.**

1. Unscrew three bracket bolts and remove bracket from rear cover.
2. Unscrew four rear cover bolts and remove rear cover from body assembly.
3. Remove gasket from body assembly.
4. Remove lock pin, cartridge and side plate from body assembly.
5. Remove pulley from drive shaft assembly.
6. Remove snap ring from drive shaft assembly and press out it.

### CAUTION:

**When removing snap ring, be careful not to damage drive shaft assembly.**

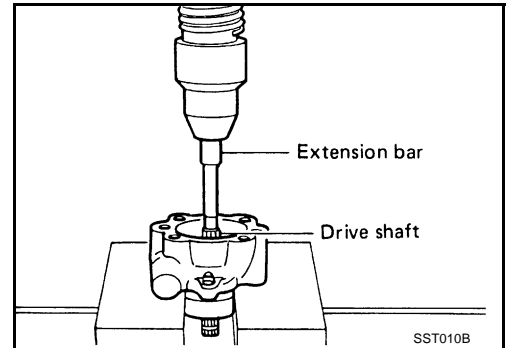

7. Using a screwdriver, remove oil seal for body assembly.
8. Remove O-ring from body assembly.

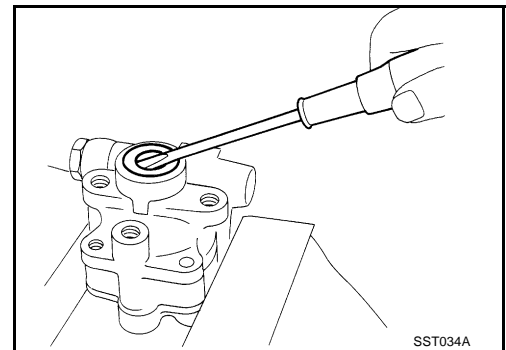

9. Loosen lock nut and remove washer, O-ring, joint then remove connector bolt, O-ring and pull out flow control valve and spring from body assembly.

### CAUTION:

**Be careful not to drop and deform the flow control valve.**

10. Remove suction pipe from body assembly.
11. Remove O-ring for suction pipe.

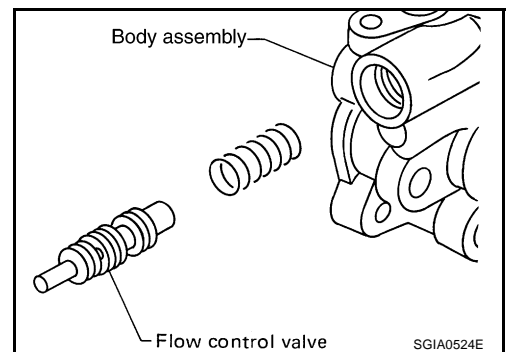

## INSPECTION AFTER DISASSEMBLY

### Body Assembly and Rear Cover Inspection

Check body assembly and the inside of rear cover for damage. If any damage is found, replace with new part for rear cover and replace with new power steering pump assembly for body assembly.

### Cartridge Assembly Inspection

Check cam ring, side plate, rotor and vane for damage. If any damage is found, replace cartridge assembly with new one.

## ASSEMBLY

### NOTE:

Fix oil pump in vise as vise occasion demands.

# POWER STEERING OIL PUMP

## CAUTION:

When retaining drive shaft assembly in a vise, always use copper or aluminum plates between vise and shaft.

1. Apply a coat of Genuine Nissan PSF or equivalent to oil seal lip and to the circumference of oil seal. Using proper tool, such as hand press machine, install it to body assembly.

### NOTE:

Do not reuse oil seal.

2. Apply a coat of Genuine Nissan PSF or equivalent to drive shaft assembly and press drive shaft assembly into body assembly with suitable tool, then install snap ring.

### NOTE:

Do not reuse snap ring.

3. Apply a coat of Genuine Nissan PSF or equivalent to O-ring and Install O-ring into body assembly.

### NOTE:

Do not reuse O-ring.

4. Install side plate to body assembly.

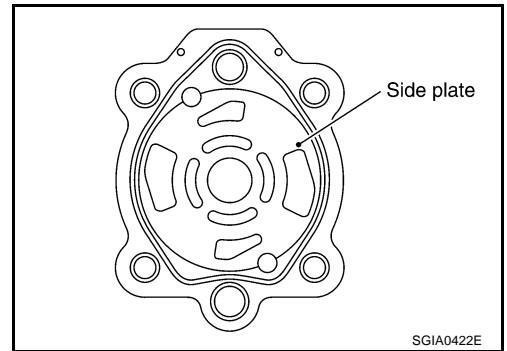
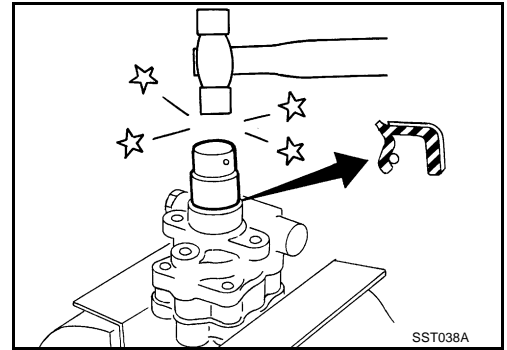

5. Install lock pin into lock pin hole, and install cam-ring as shown in the figure.

- When installing cam-ring, turn carved face with a letter (E) of it to rear cover.

## CAUTION:

Do not confuse the assembling direction of cam ring. If cam ring is installed facing the incorrect direction, it may cause pump operation malfunction.

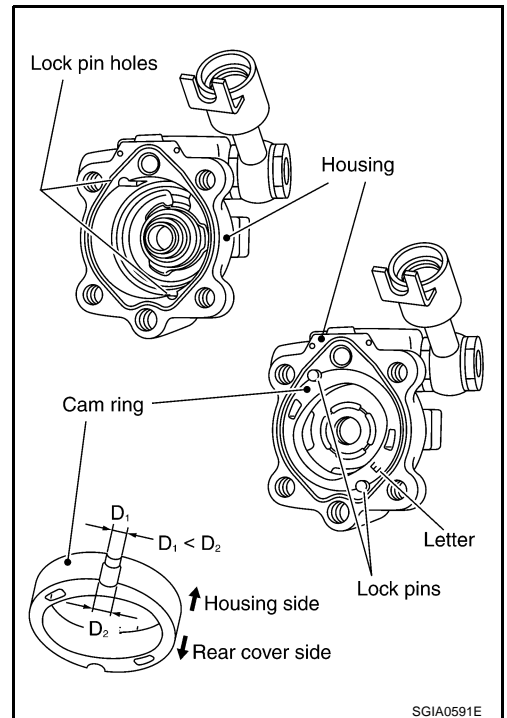

6. Install rotor to body assembly.

A  
B  
C  
D  
E  
F  
PS  
H  
I  
J  
K  
L  
M

# POWER STEERING OIL PUMP

- When installing rotor, turn punch mark face on rotor to body assembly.

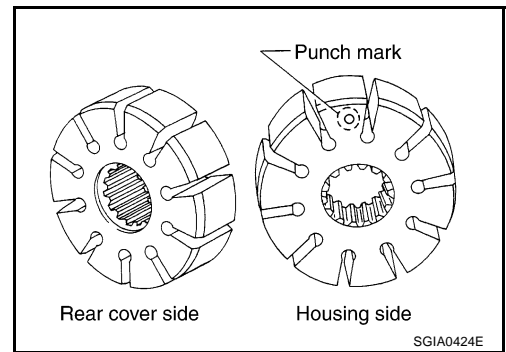

7. Install vane to rotor with facing the round portion outside.
8. Check if drive shaft assembly turns smoothly.
9. Install gasket to body assembly.

**NOTE:**

Do not reuse gasket.

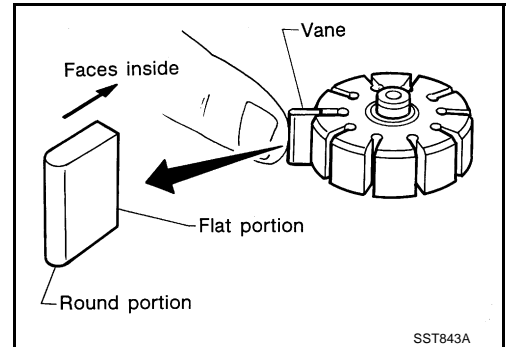

10. Install rear cover to body assembly and tighten bolts at the specified torque.
11. Install bracket to rear cover and tighten bolts at the specified torque.
12. Install pulley to drive shaft assembly then tighten lock nut at the specified torque.
13. Install spring, flow control valve, O-ring, connector bolt, joint, washer to body assembly. Then tighten lock nut at the specified torque.

**NOTE:**

Do not reuse O-ring.

14. Apply a coat of Nissan PSF or equivalent to O-ring and Install O-ring to suction pipe.

**NOTE:**

Do not reuse O-ring.

15. Install suction pipe to body assembly.

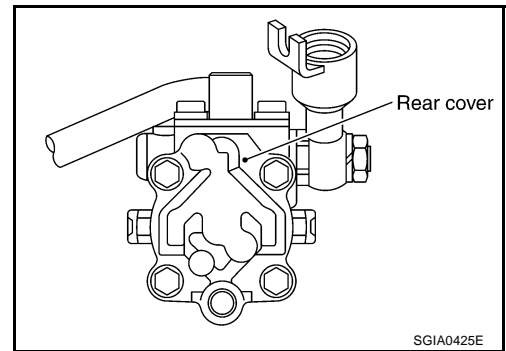



# HYDRAULIC LINE

## HYDRAULIC LINE

PFP:49721

### Components

AGS000H5

#### VQ35DE 2WD MODEL

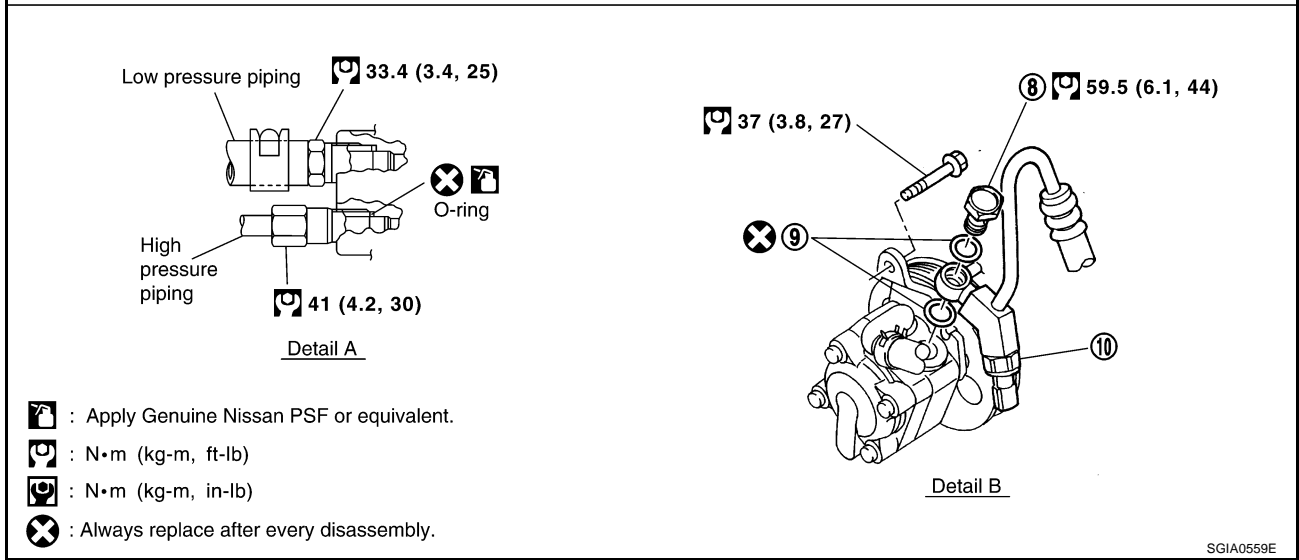
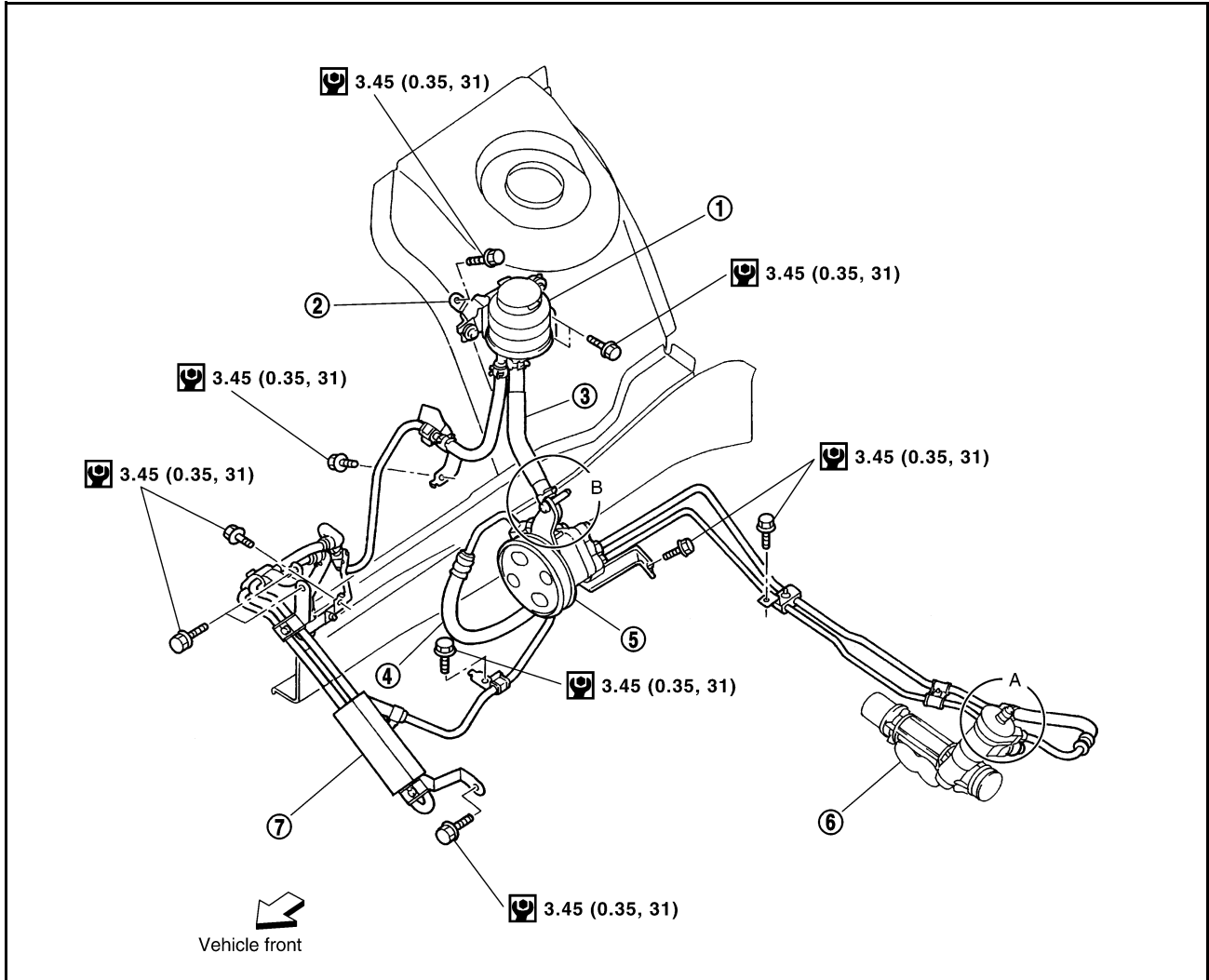

: Apply Genuine Nissan PSF or equivalent.

: N·m (kg-m, ft-lb)

: N·m (kg-m, in-lb)

: Always replace after every disassembly.

SGIA0559E

1. Reservoir tank

2. Reservoir tank bracket

3. Suction hose

4. High pressure hose

5. Oil pump

6. Steering gear assembly

# HYDRAULIC LINE

- 7. Oil cooler
- 10. Oil pressure sensor

- 8. Eye bolt

- 9. Copper washer

## VQ35DE AWD MODEL

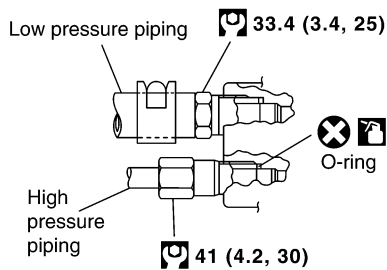
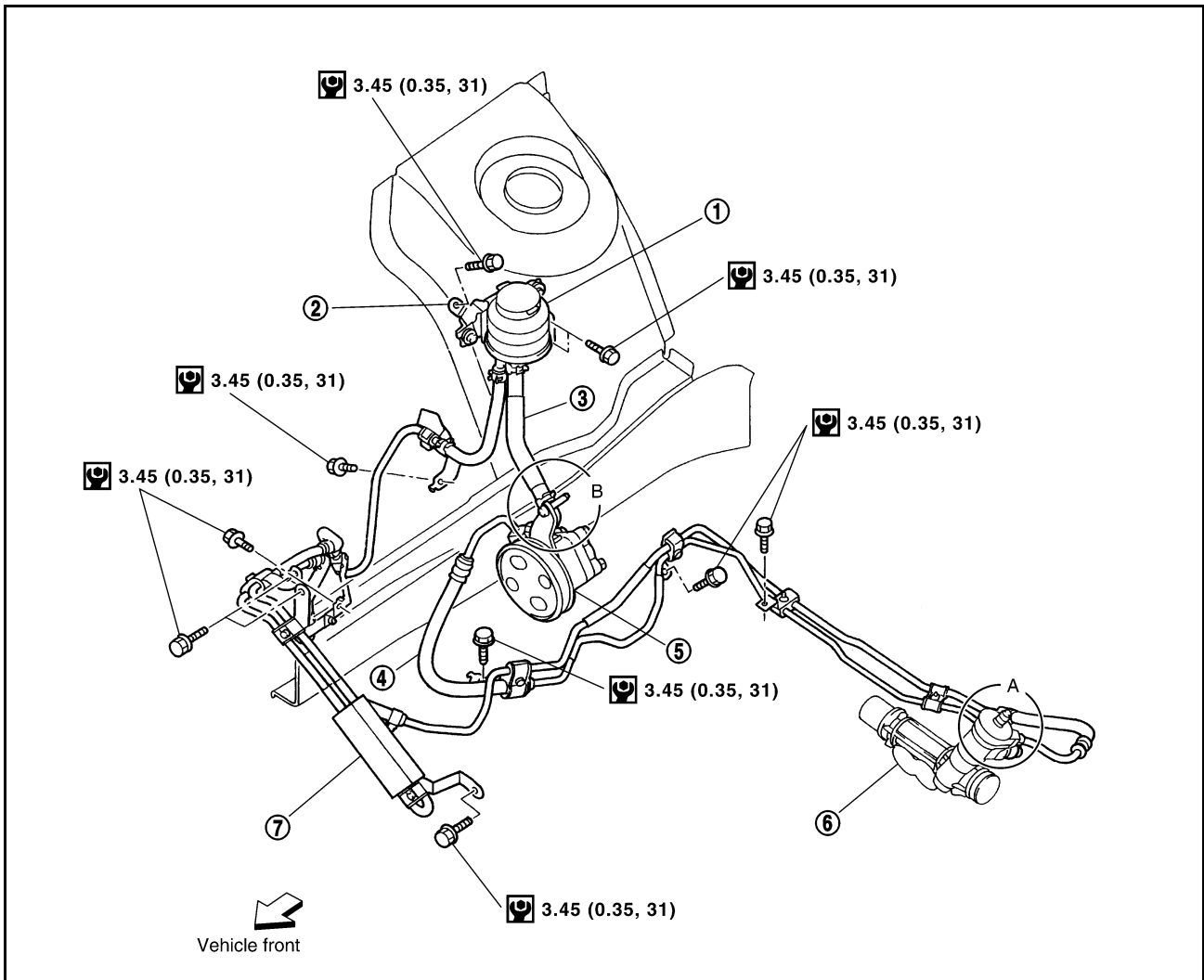

Detail A

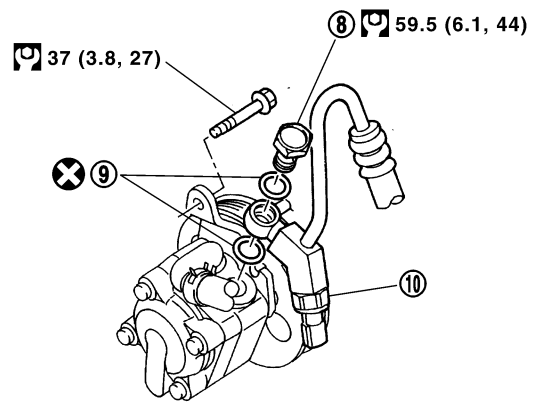

Detail B

- : Apply Genuine Nissan PSF or equivalent.
- : N·m (kg-m, ft-lb)
- : N·m (kg-m, in-lb)
- : Always replace after every disassembly.

SGIA0560E

- 1. Reservoir tank
- 4. High pressure hose
- 7. Oil cooler
- 10. Oil pressure sensor

- 2. Reservoir tank bracket
- 5. Oil pump
- 8. Eye bolt

- 3. Suction hose
- 6. Steering gear assembly
- 9. Copper washer

# HYDRAULIC LINE

## Removal and Installation

AGS000H6

- Refer to [PS-41, "Components"](#) for tightening torque. Install in the reverse order of removal.

**NOTE:**

Refer to component parts location and do not reuse non-reusable parts.

- Confirm with mating marking that it is in phase with hose and clamp, then correct if needs.

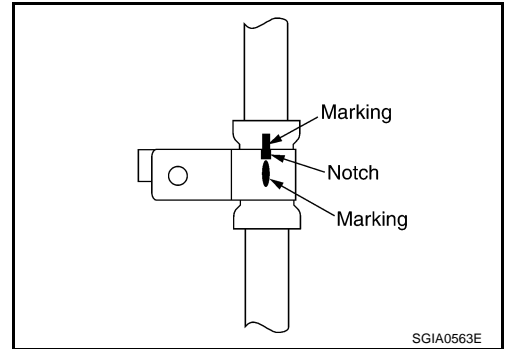

- To install eye joint, join projection of eye joint into notch of power steering pump, and attach eye joint to power steering pump properly. Then, tighten eye bolt by hands fully, and tighten it with a specified torque.
- Connect harness connector into pressure sensor securely.

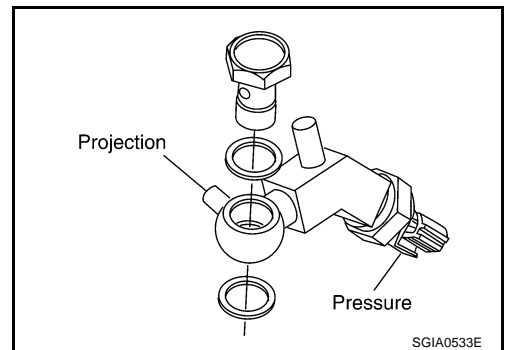

A  
B  
C  
D  
E  
F  
PS  
H  
I  
J  
K  
L  
M

# HYDRAULIC LINE

## Component

AGS000HF

### VK45DE AWD MODEL

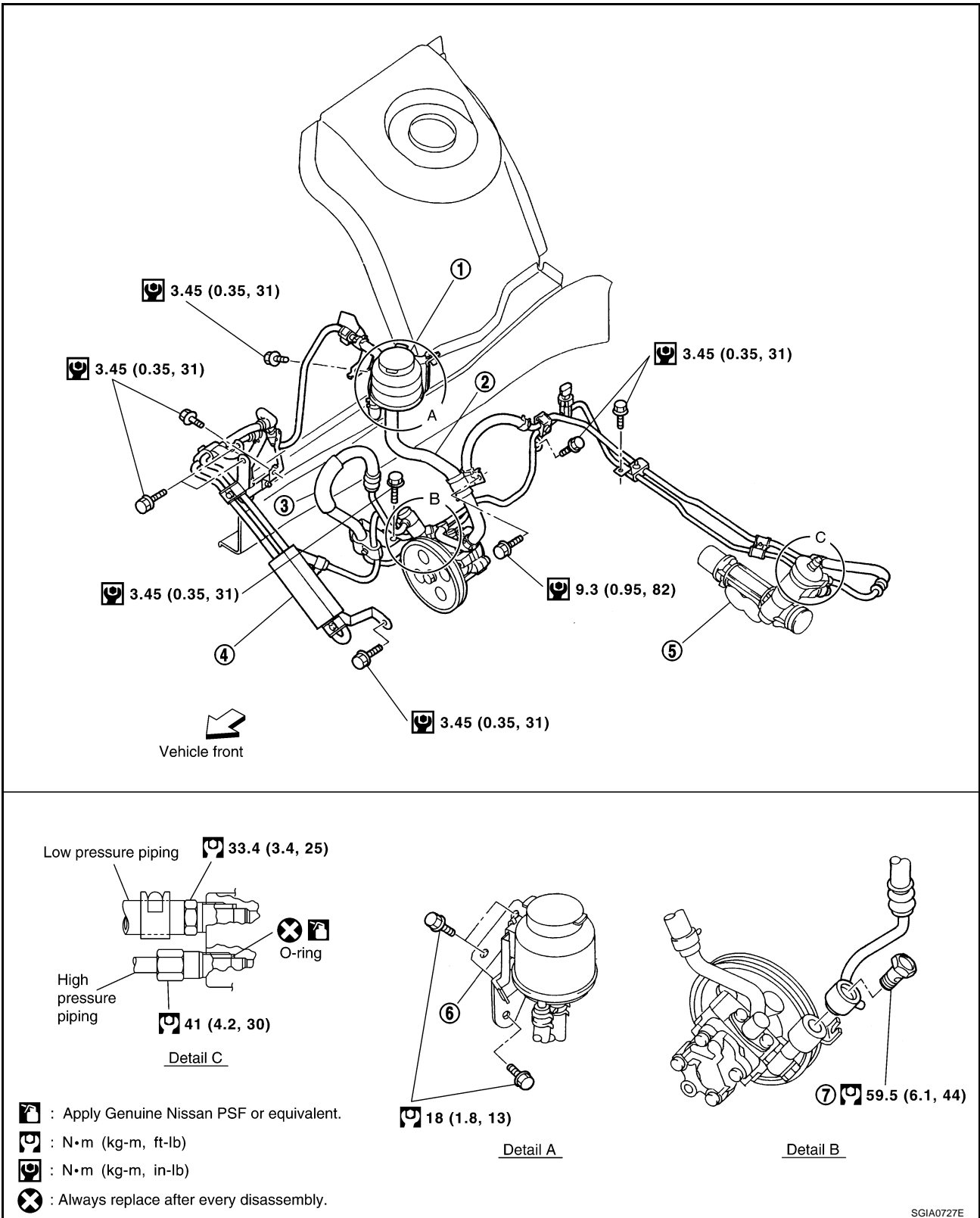

SGIA0727E

- |                   |                           |                           |
|-------------------|---------------------------|---------------------------|
| 1. Reservoir tank | 2. Suction hose           | 3. High pressure hose     |
| 4. Oil cooler     | 5. Steering gear assembly | 6. Reservoir tank bracket |
| 7. Eye bolt       |                           |                           |

# HYDRAULIC LINE

## Removal and Installation

AGS000HG

- Refer to [PS-41, "Components"](#) for tightening torque. Install in the reverse order of removal.

**NOTE:**

Refer to component parts location and do not reuse non-reusable parts.

- Confirm with mating marking that it is in phase with hose and clamp, then correct if needs.

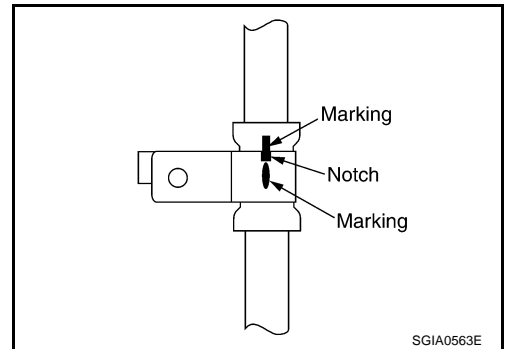

- To install eye joint, join projection of eye joint into notch of power steering pump, and attach eye joint to power steering pump properly. Then, tighten eye bolt by hands fully, and tighten it with a specified torque.

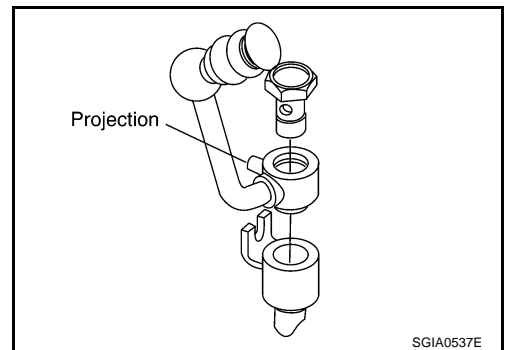

A  
B  
C  
D  
E  
F  
PS  
H  
I  
J  
K  
L  
M

# SERVICE DATA AND SPECIFICATIONS (SDS)

## SERVICE DATA AND SPECIFICATIONS (SDS)

PFP:00030

### Steering Wheel

AGS000H7

End play of the axle direction for steering wheel	0 mm (0 in)
Steering wheel play on the outer circumference	0 – 35 mm (0 – 1.38 in)

### Steering Angle

AGS000H8

Inner wheel Degree minute (Decimal degree)	Minimum	32°00' (32.0°)
	Nominal	35°00' (35.0°)
	Maximum	36°00' (36.0°)
Outer wheel Degree minute (Decimal degree)	Nominal	30°00' (30.0°)

### Steering Column

AGS000H9

Steering column length " L1 "	572 mm (22.52 in)
-------------------------------	-------------------

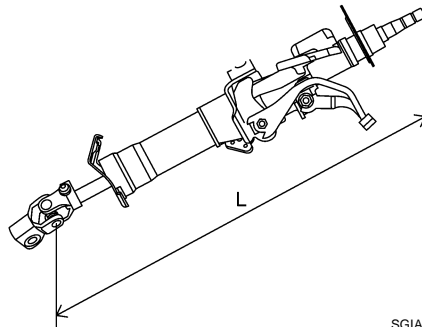

SGIA0556E

### Steering Outer Socket and Inner Socket

AGS000HA

Steering gear type		PR26AM
Tie-rod ball joint outer socket	Swinging torque	0.3 – 2.9 N·m (0.03 – 0.29 kg·m, 3 – 25 in-lb)
	Measurement on spring balance ● Measuring point: cotter pin hole of stud	4.84 – 46.7 N (0.50 – 4.7 kg, 4 – 34 lb)
	Rotating torque	0.3 – 2.9 N·m (0.03 – 0.29 kg·m, 3 – 25 in-lb)
	Axial end play	0.5 mm (0.020 in) or less
Tie-rod ball joint inner socket	Swinging torque	1.0 – 7.8 N·m (0.11 – 0.79 kg·m, 9 – 69 in-lb)
	Measurement on spring balance ● Measuring point: L mark see below, L=83.2 mm (3.276 in).	12.1 – 93.7 N (1.3 – 9.5 kg, 9 – 69 lb)
	Axial end play	0.2 mm (0.08 in) or less

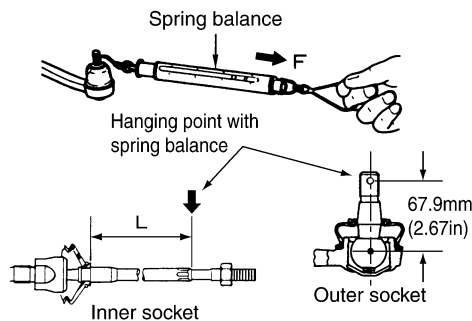

SGIA0358E

# SERVICE DATA AND SPECIFICATIONS (SDS)

Tie-rod length "L"	135.2 mm (5.32 in)
--------------------	--------------------

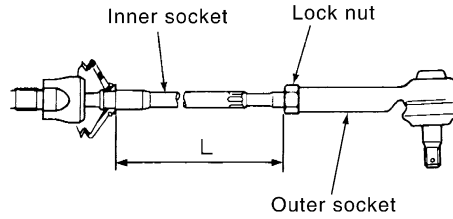

SGIA0167E

## Steering Gear

AGS000HB

Steering gear model	PR26AM
Rack neutral position, dimension "L" (rack stroke)	67.0 mm (2.638 in)

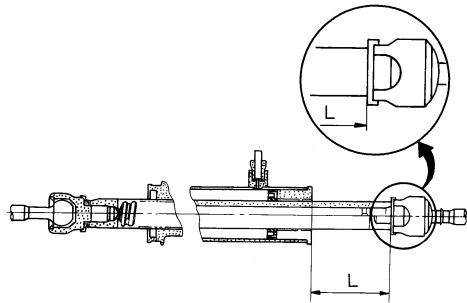

SGIA0629J

Rack sliding force	At the neutral point: Range within $\pm 11.5$ mm ( $\pm 0.453$ in) from the neutral position (in power ON)	Area average value	147 – 211 N (14.99 – 21.52 kg, 33.1 – 47.52 lb)
		Allowable variation	98 N (10 kg, 22 lb) or less
	Whole area (in power OFF)	Peak value	294 N (30.0 kg, 66 lb) or less
		Allowable variation	147 N (16 kg, 35 lb) or less

## Oil Pump

AGS000HC

Oil pump relief hydraulic pressure	9,900 – 10,700 kPa (101 – 109 kg/cm <sup>2</sup> , 1449 – 1564, psi)
------------------------------------	--

## Steering Fluid

AGS000HD

Fluid capacity	Approx. 1.0 ℓ (1-1/8 US qt, 7/8 Imp qt)
----------------	---

# SERVICE DATA AND SPECIFICATIONS (SDS)

---